



Pressure contact
 Low switching losses
 Low reverse recovery charge
 High power cycling capability
 Distributed amplified gate for high di_T/dt

Fast Stud Thyristor Type TFI271-160-14

Mean on-state current	I_{TAV}	160 A	
Repetitive peak off-state voltage	V_{DRM}	1000 ÷ 1400 V	
Repetitive peak reverse voltage	V_{RRM}		
Turn-off time	t_q	16.0; 20.0 μ s	
V_{DRM}, V_{RRM}, V	1000	1200	1400
Voltage code	10	12	14
$T_j, ^\circ C$	- 60 ÷ 125		

MAXIMUM ALLOWABLE RATINGS

Symbols and parameters		Units	Values	Test conditions
ON-STATE				
I_{TAV}	Mean on-state current	A	160 300	$T_c=95^\circ C$; $T_c=55^\circ C$; 180° half-sine wave; 50 Hz
I_{TRMS}	RMS on-state current	A	251	$T_c=95^\circ C$; 180° half-sine wave; 50 Hz
I_{TSM}	Surge on-state current	kA	5.0 5.8	180° half-sine wave; 50 Hz ($t_p=10$ ms); single pulse; $V_D=V_R=0$ V; Gate pulse: $I_G=I_{FGM}$; $V_G=20$ V; $t_{GP}=50$ μ s; $di_G/dt=1$ A/ μ s
			6.0 6.9	180° half-sine wave; 60 Hz ($t_p=8.3$ ms); single pulse; $V_D=V_R=0$ V; Gate pulse: $I_G=I_{FGM}$; $V_G=20$ V; $t_{GP}=50$ μ s; $di_G/dt=1$ A/ μ s
I^2t	Safety factor	$A^2s \cdot 10^3$	125 165	180° half-sine wave; 50 Hz ($t_p=10$ ms); single pulse; $V_D=V_R=0$ V; Gate pulse: $I_G=I_{FGM}$; $V_G=20$ V; $t_{GP}=50$ μ s; $di_G/dt=1$ A/ μ s
			145 195	180° half-sine wave; 60 Hz ($t_p=8.3$ ms); single pulse; $V_D=V_R=0$ V; Gate pulse: $I_G=I_{FGM}$; $V_G=20$ V; $t_{GP}=50$ μ s; $di_G/dt=1$ A/ μ s
BLOCKING				
V_{DRM}, V_{RRM}	Repetitive peak off-state and Repetitive peak reverse voltages	V	1000÷1400	$T_{j\ min} < T_j < T_{j\ max}$; 180° half-sine wave; 50 Hz; Gate open
V_{DSM}, V_{RSM}	Non-repetitive peak off-state and Non-repetitive peak reverse voltages	V	1100÷1500	$T_{j\ min} < T_j < T_{j\ max}$; 180° half-sine wave; 50 Hz; single pulse; Gate open
V_D, V_R	Direct off-state and Direct reverse voltages	V	0.75· V_{DRM} 0.75· V_{RRM}	$T_j=T_{j\ max}$; Gate open

TRIGGERING				
I_{FGM}	Peak forward gate current	A	6	$T_j = T_{j\max}$
V_{RGM}	Peak reverse gate voltage	V	5	
P_G	Gate power dissipation	W	3	$T_j = T_{j\max}$ for DC gate current
SWITCHING				
$(di_T/dt)_{crit}$	Critical rate of rise of on-state current non-repetitive (f=1 Hz)	A/ μ s	1600	$T_j = T_{j\max}$; $V_D = 0.67 V_{DRM}$; $I_{TM} = 2 I_{TAV}$; Gate pulse: $I_G = I_{FGM}$; $V_G = 20$ V; $t_{GP} = 50 \mu$ s; $di_G/dt = 1$ A/ μ s
THERMAL				
T_{stg}	Storage temperature	$^{\circ}$ C	-60 ÷ 125	
T_j	Operating junction temperature	$^{\circ}$ C	-60 ÷ 125	
MECHANICAL				
M	Tightening torque	Nm	25 ÷ 35	
a	Acceleration	m/s ²	100	

CHARACTERISTICS

Symbols and parameters		Units	Values	Conditions	
ON-STATE					
V_{TM}	Peak on-state voltage, max	V	2.20	$T_j = 25 \text{ }^{\circ}\text{C}$; $I_{TM} = 502$ A	
$V_{T(TO)}$	On-state threshold voltage, max	V	1.65	$T_j = T_{j\max}$;	
r_T	On-state slope resistance, max	m Ω	1.700	$0.5 \pi I_{TAV} < I_T < 1.5 \pi I_{TAV}$	
I_H	Holding current, max	mA	500	$T_j = 25 \text{ }^{\circ}\text{C}$; $V_D = 12$ V; Gate open	
BLOCKING					
I_{DRM} , I_{RRM}	Repetitive peak off-state and Repetitive peak reverse currents, max	mA	70	$T_j = T_{j\max}$; $V_D = V_{DRM}$; $V_R = V_{RRM}$	
$(dv_D/dt)_{crit}$	Critical rate of rise of off-state voltage ¹⁾ , min	V/ μ s	1000	$T_j = T_{j\max}$; $V_D = 0.67 V_{DRM}$; Gate open	
TRIGGERING					
V_{GT}	Gate trigger direct voltage, max	V	4.00 2.50 2.00	$T_j = T_{j\min}$ $T_j = 25 \text{ }^{\circ}\text{C}$ $T_j = T_{j\max}$	$V_D = 12$ V; $I_D = 3$ A; Direct gate current
I_{GT}	Gate trigger direct current, max	mA	400 250 200	$T_j = T_{j\min}$ $T_j = 25 \text{ }^{\circ}\text{C}$ $T_j = T_{j\max}$	
V_{GD}	Gate non-trigger direct voltage, min	V	0.25	$T_j = T_{j\max}$;	
I_{GD}	Gate non-trigger direct current, min	mA	10.00	$V_D = 0.67 V_{DRM}$; Direct gate current	
SWITCHING					
t_{gd}	Delay time	μ s	2.00	$T_j = 25 \text{ }^{\circ}\text{C}$; $V_D = 0.4 V_{DRM}$; $I_{TM} = I_{TAV}$; Gate pulse: $I_G = I_{FGM}$; $V_G = 20$ V; $t_{GP} = 50 \mu$ s; $di_G/dt = 1$ A/ μ s	
t_q	Turn-off time ²⁾ , max	μ s	16.0; 20.0	$dv_D/dt = 50$ V/ μ s; $T_j = T_{j\max}$; $I_{TM} = I_{TAV}$; $di_R/dt = -10$ A/ μ s; $V_R = 100$ V; $V_D = 0.67 V_{DRM}$	
Q_{rr}	Total recovered charge, max	μ C	100	$T_j = T_{j\max}$; $I_{TM} = I_{TAV}$;	
t_{rr}	Reverse recovery time, typ	μ s	3.2	$di_R/dt = -50$ A/ μ s;	
I_{rrM}	Peak reverse recovery current, max	A	63	$V_R = 100$ V	

THERMAL				
R_{thjc}	Thermal resistance, junction to case, max	$^{\circ}\text{C}/\text{W}$	0.0800	Direct current
MECHANICAL				
w	Weight, typ	g	440	
D_s	Surface creepage distance	mm (inch)	12.4 (4.882)	
D_a	Air strike distance	mm (inch)	12.4 (4.882)	

NOTES		PART NUMBERING GUIDE																												
¹⁾ Critical rate of rise of off-state voltage <table border="1"> <tr> <td>Symbol of group</td> <td colspan="2">A2</td> </tr> <tr> <td>$(dv_D/dt)_{crit}$, V/μs</td> <td colspan="2">1000</td> </tr> </table>		Symbol of group	A2		$(dv_D/dt)_{crit}$, V/ μs	1000		<table border="1"> <tr> <td>TFI</td> <td>271</td> <td>160</td> <td>14</td> <td>A2</td> <td>T3</td> <td colspan="2">N</td> </tr> <tr> <td>1</td> <td>2</td> <td>3</td> <td>4</td> <td>5</td> <td>6</td> <td colspan="2">7</td> </tr> </table>							TFI	271	160	14	A2	T3	N		1	2	3	4	5	6	7	
Symbol of group	A2																													
$(dv_D/dt)_{crit}$, V/ μs	1000																													
TFI	271	160	14	A2	T3	N																								
1	2	3	4	5	6	7																								
²⁾ Turn-off time ($dv_D/dt=50$ V/ μs) <table border="1"> <tr> <td>Symbol of group</td> <td>T3</td> <td>P3</td> </tr> <tr> <td>t_{qr}, μs</td> <td>16.0</td> <td>20.0</td> </tr> </table>		Symbol of group	T3	P3	t_{qr} , μs	16.0	20.0	<ol style="list-style-type: none"> High Frequency Inverter Grade Thyristor Design version Mean on-state current, A Voltage code Critical rate of rise of off-state voltage Group of turn-off time ($dv_D/dt=50$ V/μs) Ambient conditions: N – normal; T – tropical 																						
Symbol of group	T3	P3																												
t_{qr} , μs	16.0	20.0																												

OVERALL DIMENSIONS

Package type: T.SB1

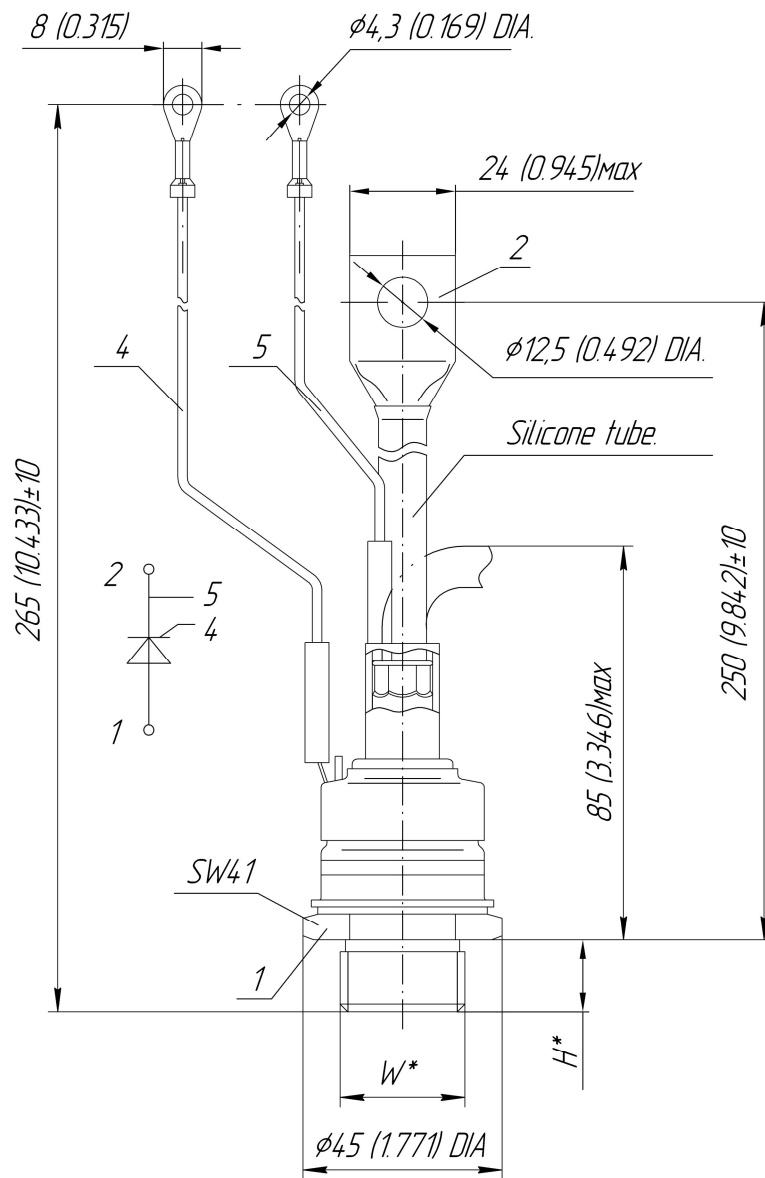

Type of screw	W	H
Metric Screw Type C	M24x1,5	18
Metric Screw Type B (upon request)	M20x1,5	18

Polarity	Example of code designation	Reference designation	Colors		
			Anode	Cathode	Gate
Anode to stud	TFI271-160-14		-	Red tube	White

All dimensions in millimeters (inches)

The information contained herein is confidential and protected by Copyright. In the interest of product improvement, Proton-Electrotex reserves the right to change data sheet without notice.