



Optimum power handling  
Low on-state and switching losses  
Designed for traction and industrial applications

**Phase Control Stud Thyristor**  
**Type T471-250-16**

Mean on-state current	$I_{TAV}$	250 A															
Repetitive peak off-state voltage*	$V_{DRM}$	100÷1600 V															
Repetitive peak reverse voltage*	$V_{RRM}$																
Turn-off time	$t_q$	125 $\mu$ s															
$V_{DRM}, V_{RRM}, V$		100	200	300	400	500	600	700	800	900	1000	1100	1200	1300	1400	1500	1600
Voltage code		1	2	3	4	5	6	7	8	9	10	11	12	13	14	15	16
$T_{jv}, ^\circ C$		-60÷125															

\* **1800 V** – Voltage class on demand

**MAXIMUM ALLOWABLE RATINGS**

Symbols and parameters		Units	Values	Test conditions
<b>ON-STATE</b>				
$I_{TAV}$	Mean on-state current	A	250 295	$T_c = 93\text{ }^\circ C$ ; $T_c = 85\text{ }^\circ C$ ; 180° half-sine wave; 50 Hz
$I_{TRMS}$	RMS on-state current	A	393	$T_c = 93\text{ }^\circ C$ ; 180° half-sine wave; 50 Hz
$I_{TSM}$	Surge on-state current	kA	9.0 10.4	$T_j = T_{jmax}$ $T_j = 25\text{ }^\circ C$ 180° half-sine wave; 50 Hz ( $t_p = 10\text{ ms}$ ); single pulse; $V_D = V_R = 0\text{ V}$ ; Gate pulse: $I_G = 2\text{ A}$ ; $t_{GP} = 50\text{ }\mu s$ ; $di_G/dt \geq 1\text{ A}/\mu s$
			10.0 11.5	$T_j = T_{jmax}$ $T_j = 25\text{ }^\circ C$ 180° half-sine wave; 60 Hz ( $t_p = 8.3\text{ ms}$ ); single pulse; $V_D = V_R = 0\text{ V}$ ; Gate pulse: $I_G = 2\text{ A}$ ; $t_{GP} = 50\text{ }\mu s$ ; $di_G/dt \geq 1\text{ A}/\mu s$
$I^2t$	Safety factor	$A^2s \cdot 10^3$	405 540	$T_j = T_{jmax}$ $T_j = 25\text{ }^\circ C$ 180° half-sine wave; 50 Hz ( $t_p = 10\text{ ms}$ ); single pulse; $V_D = V_R = 0\text{ V}$ ; Gate pulse: $I_G = 2\text{ A}$ ; $t_{GP} = 50\text{ }\mu s$ ; $di_G/dt \geq 1\text{ A}/\mu s$
			415 545	$T_j = T_{jmax}$ $T_j = 25\text{ }^\circ C$ 180° half-sine wave; 60 Hz ( $t_p = 8.3\text{ ms}$ ); single pulse; $V_D = V_R = 0\text{ V}$ ; Gate pulse: $I_G = 2\text{ A}$ ; $t_{GP} = 50\text{ }\mu s$ ; $di_G/dt \geq 1\text{ A}/\mu s$
<b>BLOCKING</b>				
$V_{DRM}, V_{RRM}$	Repetitive peak off-state and Repetitive peak reverse voltages	V	100÷1600	$T_{jmin} < T_j < T_{jmax}$ ; 180° half-sine wave; 50 Hz; Gate open
$V_{DSM}, V_{RSM}$	Non-repetitive peak off-state and Non-repetitive peak reverse voltages	V	110÷1700	$T_{jmin} < T_j < T_{jmax}$ ; 180° half-sine wave; 50 Hz; single pulse; Gate open
$V_D, V_R$	Direct off-state and Direct reverse voltages	V	$0.75 \cdot V_{DRM}$ $0.75 \cdot V_{RRM}$	$T_j = T_{jmax}$ ; Gate open

<b>TRIGGERING</b>				
$I_{FGM}$	Peak forward gate current	A	6	$T_j = T_{j\ max}$
$V_{RGM}$	Peak reverse gate voltage	V	5	
$P_G$	Gate power dissipation	W	3	$T_j = T_{j\ max}$ for DC gate current
<b>SWITCHING</b>				
$(di_T/dt)_{crit}$	Critical rate of rise of on-state current non-repetitive (f=1 Hz)	A/ $\mu$ s	320	$T_j = T_{j\ max}; V_D = 0.67 \cdot V_{DRM}; I_{TM} = 2 I_{TAV};$ Gate pulse: $I_G = 2\ A;$ $t_{GP} = 50\ \mu s; di_G/dt \geq 1\ A/\mu s$
<b>THERMAL</b>				
$T_{stg}$	Storage temperature	$^{\circ}C$	-60÷125	
$T_j$	Operating junction temperature	$^{\circ}C$	-60÷125	
<b>MECHANICAL</b>				
M	Tightening torque	Nm	25÷35	
a	Acceleration	m/s <sup>2</sup>	100	

## CHARACTERISTICS

Symbols and parameters		Units	Values	Conditions	
<b>ON-STATE</b>					
$V_{TM}$	Peak on-state voltage, max	V	1.75	$T_j = 25\ ^{\circ}C; I_{TM} = 785\ A$	
$V_{T(TO)}$	On-state threshold voltage, max	V	1.00	$T_j = T_{j\ max};$	
$r_T$	On-state slope resistance, max	m $\Omega$	0.950	$0.5\ \pi\ I_{TAV} < I_T < 1.5\ \pi\ I_{TAV}$	
$I_L$	Latching current, max	mA	700	$T_j = 25\ ^{\circ}C; V_D = 12\ V;$ Gate pulse: $I_G = 2\ A;$ $t_{GP} = 50\ \mu s; di_G/dt \geq 1\ A/\mu s$	
$I_H$	Holding current, max	mA	300	$T_j = 25\ ^{\circ}C;$ $V_D = 12\ V;$ Gate open	
<b>BLOCKING</b>					
$I_{DRM}, I_{RRM}$	Repetitive peak off-state and Repetitive peak reverse currents, max	mA	70	$T_j = T_{j\ max};$ $V_D = V_{DRM}; V_R = V_{RRM}$	
$(dv_D/dt)_{crit}$	Critical rate of rise of off-state voltage <sup>1)</sup> , min	V/ $\mu$ s	1000	$T_j = T_{j\ max};$ $V_D = 0.67 \cdot V_{DRM};$ Gate open	
<b>TRIGGERING</b>					
$V_{GT}$	Gate trigger direct voltage, max	V	4.00 2.50 2.00	$T_j = T_{j\ min}$ $T_j = 25\ ^{\circ}C$ $T_j = T_{j\ max}$	$V_D = 12\ V; I_D = 3\ A;$ Direct gate current
$I_{GT}$	Gate trigger direct current, max	mA	400 250 200	$T_j = T_{j\ min}$ $T_j = 25\ ^{\circ}C$ $T_j = T_{j\ max}$	
$V_{GD}$	Gate non-trigger direct voltage, min	V	0.25	$T_j = T_{j\ max};$ $V_D = 0.67 \cdot V_{DRM};$	
$I_{GD}$	Gate non-trigger direct current, min	mA	10.00	Direct gate current	
<b>SWITCHING</b>					
$t_{gd}$	Delay time	$\mu$ s	2.00	$T_j = 25\ ^{\circ}C; V_D = 0.4 \cdot V_{DRM}; I_{TM} = I_{TAV};$ Gate pulse: $I_G = 2\ A;$ $t_{GP} = 50\ \mu s; di_G/dt \geq 1\ A/\mu s$	
$t_q$	Turn-off time <sup>2)</sup> , max	$\mu$ s	125	$dv_D/dt = 50\ V/\mu s; T_j = T_{j\ max}; I_{TM} = I_{TAV};$ $di_R/dt = -10\ A/\mu s; V_R = 100V;$ $V_D = 0.67 \cdot V_{DRM};$	

<b>THERMAL</b>				
R <sub>thjc</sub>	Thermal resistance, junction to case, max	°C/W	0.0800	Direct current
<b>MECHANICAL</b>				
w	Weight, typ	g	470	
D <sub>s</sub>	Surface creepage distance	mm (inch)	12.40 (4.882)	
D <sub>a</sub>	Air strike distance	mm (inch)	12.40 (4.882)	

### **PART NUMBERING GUIDE**

T	471	250	16	N
1	2	3	4	5

1. Phase Control Thyristor
2. Design version
3. Mean on-state current, A
4. Voltage code
5. Ambient conditions: N – normal; T – tropical

**OVERALL DIMENSIONS**

**Package type: T.SB2**

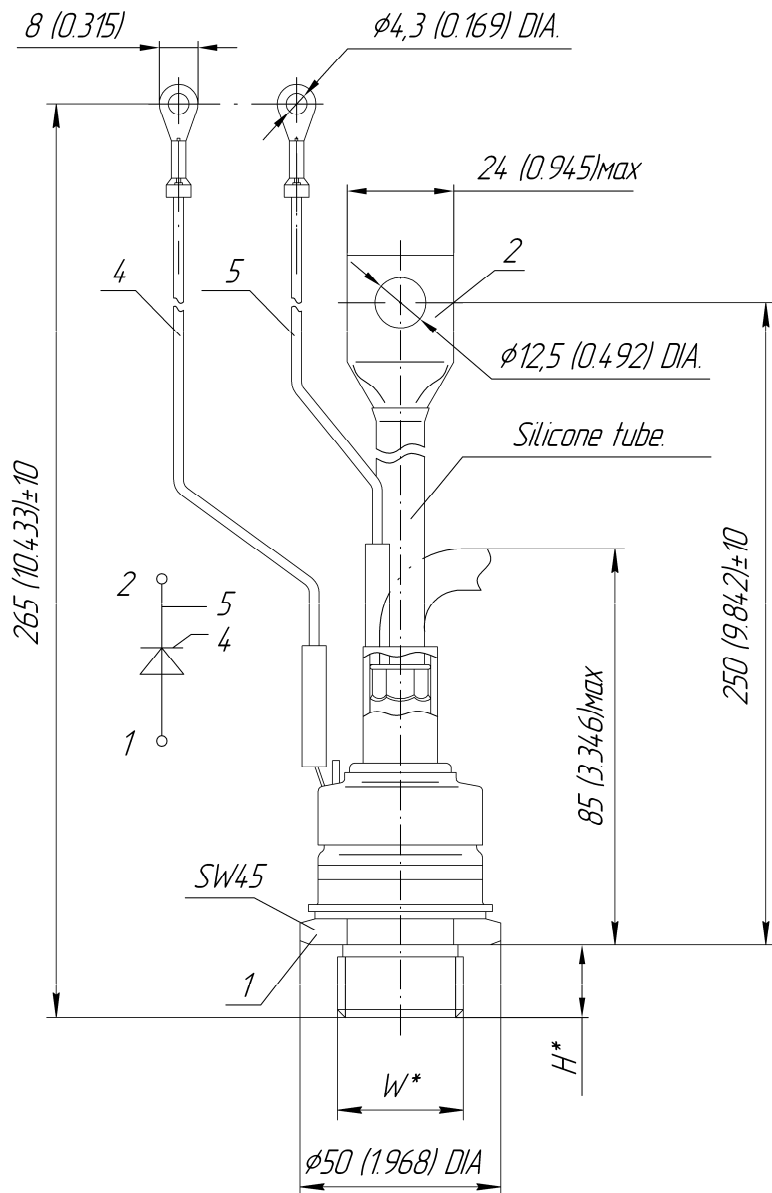

Type of screw	W	H
Metric Screw Type C	M24x1,5	18
Metric Screw Type B (upon request)	M20x1,5	18

Polarity	Example of code designation	Reference designation	Colors		
			Anode	Cathode	Gate
Anode to stud	T471-250-16		-	Red tube	White

All dimensions in millimeters (inches)

The information contained herein is confidential and protected by Copyright. In the interest of product improvement, Proton-Electrotex reserves the right to change data sheet without notice.