



Optimum power handling
Low switching losses
Low reverse recovery charge
High power cycling capability

Fast Recovery Stud Diode Type DF261-250-16

| | | | | |
|---------------------------------|------------|-----------|---------------|------|
| Mean on-state current | | I_{FAV} | 250 A | |
| Repetitive peak reverse voltage | | V_{RRM} | 1000 ÷ 1600 V | |
| Reverse recovery time | | t_{rr} | 2.5 μs | |
| V_{RRM} , V | 1000 | 1200 | 1400 | 1600 |
| Voltage code | 10 | 12 | 14 | 16 |
| T_j , °C | - 60 ÷ 150 | | | |

MAXIMUM ALLOWABLE RATINGS

| Symbols and parameters | | Units | Values | Test conditions |
|------------------------|--------------------------------------|-------------------|----------------------|--|
| ON-STATE | | | | |
| I_{FAV} | Average forward current | A | 250 405 | $T_c=101$ °C; $T_c=55$ °C; 180° half-sine wave; 50 Hz |
| I_{FRMS} | RMS forward current | A | 392 | $T_c=101$ °C; 180° half-sine wave; 50 Hz |
| I_{FSM} | Surge forward current | kA | 4.5 5.2 | $T_j=T_{j\max}$ $T_j=25$ °C 180° half-sine wave; 50 Hz ($t_p=10$ ms); single pulse; $V_R=0$ V; |
| | | | 5.0 5.8 | $T_j=T_{j\max}$ $T_j=25$ °C 180° half-sine wave; 60 Hz ($t_p=8.3$ ms); single pulse; $V_R=0$ V; |
| I^2t | Safety factor | $A^2s \cdot 10^3$ | 100 135 | $T_j=T_{j\max}$ $T_j=25$ °C 180° half-sine wave; 50 Hz ($t_p=10$ ms); single pulse; $V_R=0$ V; |
| | | | 105 140 | $T_j=T_{j\max}$ $T_j=25$ °C 180° half-sine wave; 60 Hz ($t_p=8.3$ ms); single pulse; $V_R=0$ V; |
| BLOCKING | | | | |
| V_{RRM} | Repetitive peak reverse voltages | V | 1000÷1600 | $T_{j\min} < T_j < T_{j\max}$; 180° half-sine wave; 50 Hz; |
| V_{RSM} | Non-repetitive peak reverse voltages | V | 1100÷1700 | $T_{j\min} < T_j < T_{j\max}$; 180° half-sine wave; 50 Hz; single pulse; |
| V_R | Reverse continuous voltages | V | $0.75 \cdot V_{RRM}$ | $T_j=T_{j\max}$; |
| THERMAL | | | | |
| T_{stg} | Storage temperature | °C | - 60 ÷ 150 | |
| T_j | Operating junction temperature | °C | - 60 ÷ 150 | |
| MECHANICAL | | | | |
| M | Tightening torque | Nm | 20 ÷ 30 | |
| a | Acceleration | m/s ² | 100 | |

CHARACTERISTICS

| Symbols and parameters | | Units | Values | Conditions |
|------------------------|---|---------------------------|-----------------|---|
| ON-STATE | | | | |
| V_{FM} | Peak forward voltage, max | V | 2.10 | $T_j=25\text{ }^\circ\text{C}; I_{FM}=785\text{ A}$ |
| $V_{F(TO)}$ | Forward threshold voltage, max | V | 1.25 | $T_j=T_{j\text{ max}};$ $0.5\pi I_{FAV} < I_T < 1.5\pi I_{FAV}$ |
| r_T | Forward slope resistance, max | m Ω | 1.100 | |
| BLOCKING | | | | |
| I_{RRM} | Repetitive peak reverse current, max | mA | 40 | $T_j=T_{j\text{ max}};$ $V_R=V_{RRM}$ |
| SWITCHING | | | | |
| Q_{rr} | Total recovered charge, max | μC | 250 | $T_j=T_{j\text{ max}}; I_{FM}=250\text{ A};$ $di_R/dt=-100\text{ A}/\mu\text{s};$ $V_R=100\text{ V};$ |
| t_{rr} | Reverse recovery time, max | μs | 2.5 | |
| I_{rrM} | Peak reverse recovery current, max | A | 200 | |
| THERMAL | | | | |
| R_{thjc} | Thermal resistance, junction to case, max | $^\circ\text{C}/\text{W}$ | 0.1000 | Direct current |
| MECHANICAL | | | | |
| w | Weight, typ | g | 250 | |
| D_s | Surface creepage distance | mm (inch) | 12.4 (4.882) | |
| D_a | Air strike distance | mm (inch) | 12.4 (4.882) | |

| PART NUMBERING GUIDE | | | | | | | GROUP OF RECOVERY TIME | |
|--|-----|-----|---|----|----|---|------------------------|-----|
| DF | 261 | 250 | | 16 | M4 | N | Group Symbol | M4 |
| 1 | 2 | 3 | 4 | 5 | 6 | 7 | $t_{rr}, \mu\text{s}$ | 2.5 |
| 1. Fast recovery diode 2. Design version 3. Average forward current, A 4. Polarity: X – Cathode to Stud; Anode to Stud – no symbol 5. Voltage code 6. Group of reverse recovery time 7. Ambient conditions: N – normal; T – tropical | | | | | | | | |

JSC "PROTON-ELECTROTEX"

19 Leskova, 302027, Orel, RUSSIA, Fax : +7 (4862) 41-00-56 Phones : +7 (4862) 43-41-39 / 43-41-40

E-mail: eletex@eletex.ru / eltex@orel.ru; I-net: www.eletex.ru

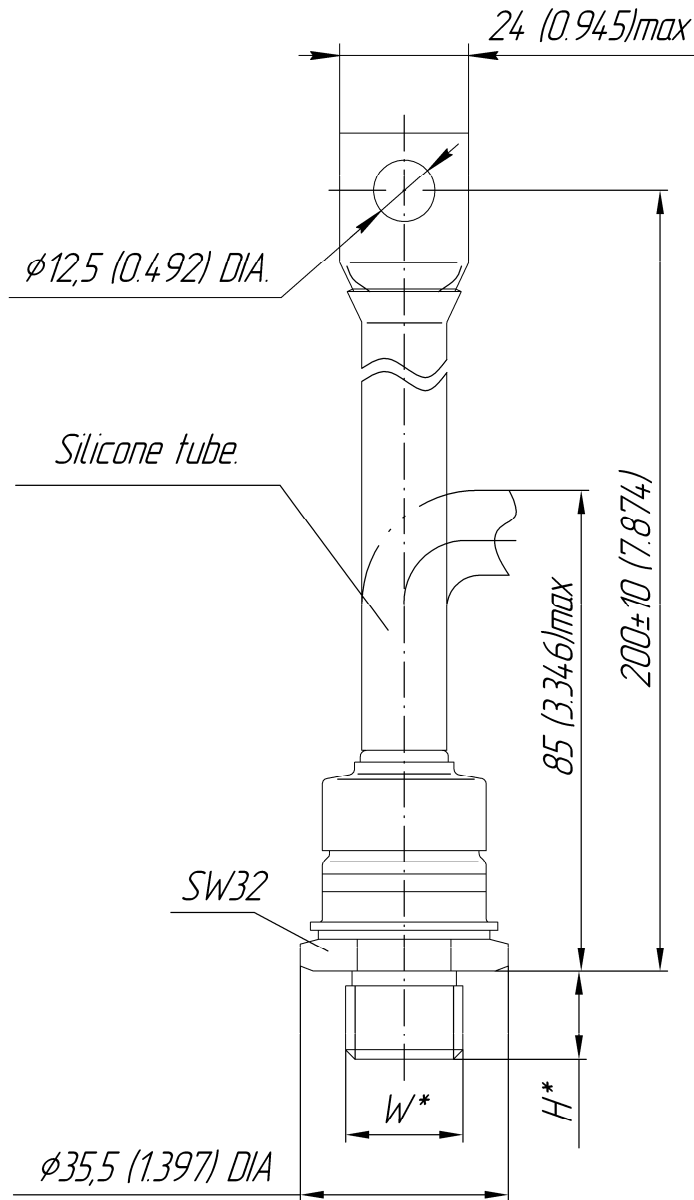

| Type of screw | W | H |
|------------------------------------|---------|----|
| Metric Screw Type B | M20x1,5 | 16 |
| Metric Screw Type A (upon request) | M16x1,5 | 13 |

| Polarity | Example of code designation | Reference designation | Colors | |
|----------|-----------------------------|-----------------------|------------|----------|
| | | | Anode | Cathode |
| Normal | Anode to stud | DF261-250-16 | - | Red tube |
| Reverse | Cathode to stud | DF261-250X-16 | Black tube | - |

All dimensions in millimeters (inches)

The information contained herein is confidential and protected by Copyright.
In the interest of product improvement, Proton-Electrotex reserves the right to change data sheet without notice.

JSC "PROTON-ELECTROTEX"

19 Leskova, 302027, Orel, RUSSIA, Fax : +7 (4862) 41-00-56 Phones : +7 (4862) 43-41-39 / 43-41-40

E-mail: eletex@eletex.ru / eltex@orel.ru; I-net: www.eletex.ru