

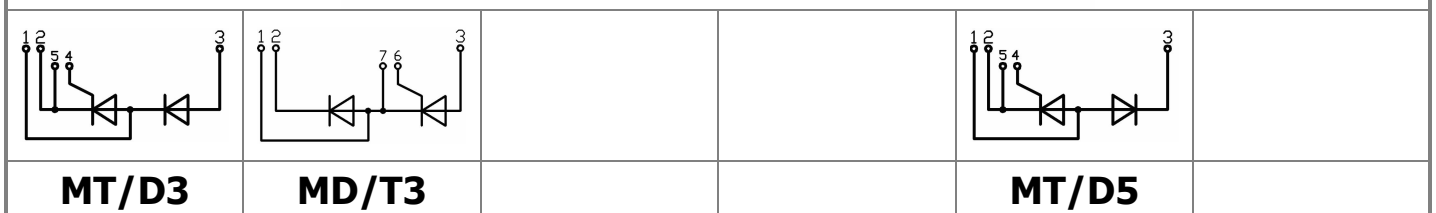

Electrically isolated base plate
Industrial standard package
Simplified mechanical design, rapid assembly
Pressure contact

Double Thyristor Module
For Phase Control
MTx-201-18-F

| | | | | | |
|-----------------------------------|------------|------|-----------|---------------|------|
| Mean on-state current | | | I_{TAV} | 201 A | |
| Repetitive peak off-state voltage | | | V_{DRM} | 1000 ÷ 1800 V | |
| Repetitive peak reverse voltage | | | V_{RRM} | | |
| Turn-off time | | | t_q | 125 μ s | |
| V_{DRM}, V_{RRM}, V | 1000 | 1200 | 1400 | 1600 | 1800 |
| Voltage code | 10 | 12 | 14 | 16 | 18 |
| $T_{jv}, ^\circ C$ | - 40 ÷ 130 | | | | |

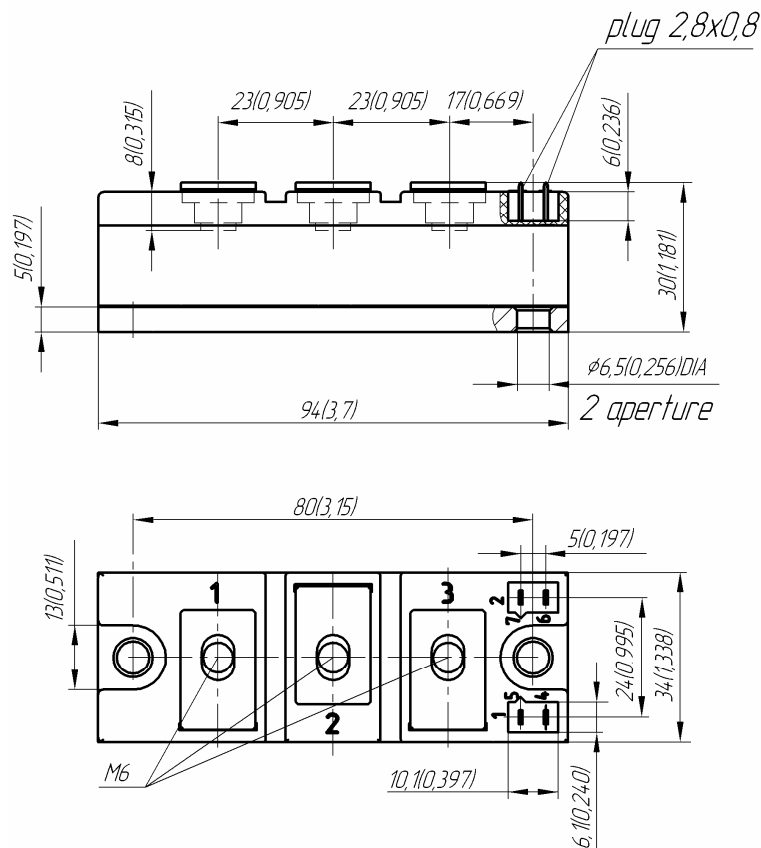
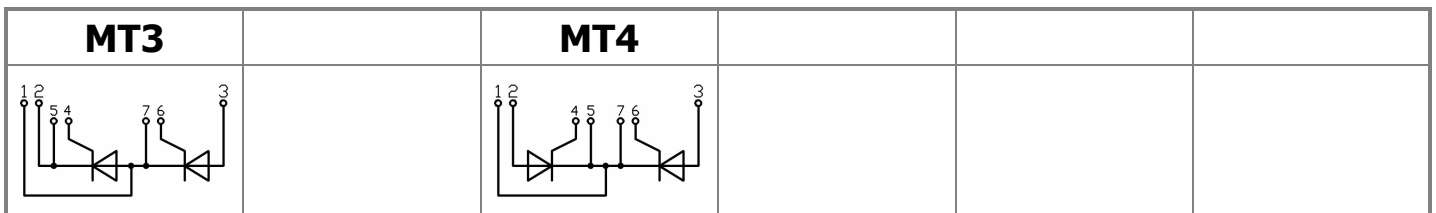

MAXIMUM ALLOWABLE RATINGS

| Symbols and parameters | | Units | Values | Test conditions |
|------------------------|---|------------------|--|---|
| ON-STATE | | | | |
| I_{TAV} | Mean on-state current | A | 201 | $T_c=85\text{ }^\circ\text{C}$; 180° half-sine wave; 50 Hz |
| I_{TRMS} | RMS on-state current | A | 315 | |
| I_{TSM} | Surge on-state current | kA | 6.0 7.0 | $T_j=T_{j\text{ max}}$ $T_j=25\text{ }^\circ\text{C}$ 180° half-sine wave; 50 Hz ($t_p=10\text{ ms}$); single pulse; $V_D=V_R=0\text{ V}$; Gate pulse: $I_G=2\text{ A}$; $t_{GP}=50\text{ }\mu\text{s}$; $di_G/dt\geq 1\text{ A}/\mu\text{s}$ |
| | | | 7.0 8.0 | $T_j=T_{j\text{ max}}$ $T_j=25\text{ }^\circ\text{C}$ 180° half-sine wave; 60 Hz ($t_p=8.3\text{ ms}$); single pulse; $V_D=V_R=0\text{ V}$; Gate pulse: $I_G=2\text{ A}$; $t_{GP}=50\text{ }\mu\text{s}$; $di_G/dt\geq 1\text{ A}/\mu\text{s}$ |
| I^2t | Safety factor | $A^2s\cdot 10^3$ | 180 245 | $T_j=T_{j\text{ max}}$ $T_j=25\text{ }^\circ\text{C}$ 180° half-sine wave; 50 Hz ($t_p=10\text{ ms}$); single pulse; $V_D=V_R=0\text{ V}$; Gate pulse: $I_G=2\text{ A}$; $t_{GP}=50\text{ }\mu\text{s}$; $di_G/dt\geq 1\text{ A}/\mu\text{s}$ |
| | | | 200 265 | $T_j=T_{j\text{ max}}$ $T_j=25\text{ }^\circ\text{C}$ 180° half-sine wave; 60 Hz ($t_p=8.3\text{ ms}$); single pulse; $V_D=V_R=0\text{ V}$; Gate pulse: $I_G=2\text{ A}$; $t_{GP}=50\text{ }\mu\text{s}$; $di_G/dt\geq 1\text{ A}/\mu\text{s}$ |
| BLOCKING | | | | |
| V_{DRM}, V_{RRM} | Repetitive peak off-state and Repetitive peak reverse voltages | V | 1000÷1800 | $T_{j\text{ min}} < T_j < T_{j\text{ max}}$; 180° half-sine wave; 50 Hz; Gate open |
| V_{DSM}, V_{RSM} | Non-repetitive peak off-state and Non-repetitive peak reverse voltages | V | 1100÷1900 | $T_{j\text{ min}} < T_j < T_{j\text{ max}}$; 180° half-sine wave; 50 Hz; single pulse; Gate open |
| V_D, V_R | Direct off-state and Direct reverse voltages | V | $0.75\cdot V_{DRM}$ $0.75\cdot V_{RRM}$ | $T_j=T_{j\text{ max}}$; Gate open |
| TRIGGERING | | | | |
| I_{FGM} | Peak forward gate current | A | 5 | $T_j=T_{j\text{ max}}$ |
| V_{RGM} | Peak reverse gate voltage | V | 5 | |
| P_G | Gate power dissipation | W | 3 | $T_j=T_{j\text{ max}}$ for DC gate current |
| SWITCHING | | | | |
| $(di_T/dt)_{crit}$ | Critical rate of rise of on-state current non-repetitive (f=1 Hz) | $A/\mu\text{s}$ | 500 | $T_j=T_{j\text{ max}}$; $V_D=0.67\cdot V_{DRM}$; $I_{TM}=2\text{ }I_{TAV}$; Gate pulse: $I_G=2\text{ A}$; $t_{GP}=50\text{ }\mu\text{s}$; $di_G/dt\geq 1\text{ A}/\mu\text{s}$ |
| THERMAL | | | | |
| T_{stg} | Storage temperature | $^\circ\text{C}$ | -40 ÷ 125 | |
| T_j | Operating junction temperature | $^\circ\text{C}$ | -40 ÷ 130 | |
| MECHANICAL | | | | |
| a | Acceleration under vibration | m/s^2 | 50 | |

CHARACTERISTICS

| Symbols and parameters | | Units | Values | Conditions | |
|------------------------|--|---------------------------|----------------------|--|---|
| ON-STATE | | | | | |
| V_{TM} | Peak on-state voltage, max | V | 1.40 | $T_j=25\text{ }^\circ\text{C}; I_{TM}=500\text{ A}$ | |
| $V_{T(TO)}$ | On-state threshold voltage, max | V | 0.80 | $T_j=T_{j\text{ max}}$ | |
| r_T | On-state slope resistance, max | m Ω | 0.970 | $0.5\pi I_{TAV} < I_T < 1.5\pi I_{TAV}$ | |
| I_L | Latching current, max | mA | 500 | $T_j=25\text{ }^\circ\text{C}; V_D=12\text{ V};$ Gate pulse: $I_G=2\text{ A};$ $t_{GP}=50\text{ }\mu\text{s}; di_G/dt \geq 1\text{ A}/\mu\text{s}$ | |
| I_H | Holding current, max | mA | 250 | $T_j=25\text{ }^\circ\text{C};$ $V_D=12\text{ V};$ Gate open | |
| BLOCKING | | | | | |
| I_{DRM}, I_{RRM} | Repetitive peak off-state and Repetitive peak reverse currents, max | mA | 30 | $T_j=T_{j\text{ max}};$ $V_D=V_{DRM}; V_R=V_{RRM}$ | |
| $(dv_D/dt)_{crit}$ | Critical rate of rise of off-state voltage, min | V/ μs | 1000 | $T_j=T_{j\text{ max}};$ $V_D=0.67 \cdot V_{DRM};$ Gate open | |
| TRIGGERING | | | | | |
| V_{GT} | Gate trigger direct voltage, max | V | 4.00 2.50 2.00 | $T_j=T_{j\text{ min}}$ $T_j=25\text{ }^\circ\text{C}$ $T_j=T_{j\text{ max}}$ | $V_D=12\text{ V}; I_D=3\text{ A};$ Direct gate current |
| I_{GT} | Gate trigger direct current, max | mA | 400 250 200 | $T_j=T_{j\text{ min}}$ $T_j=25\text{ }^\circ\text{C}$ $T_j=T_{j\text{ max}}$ | |
| V_{GD} | Gate non-trigger direct voltage, min | V | 0.25 | $T_j=T_{j\text{ max}};$ $V_D=0.67 \cdot V_{DRM};$ | |
| I_{GD} | Gate non-trigger direct current, min | mA | 10.00 | Direct gate current | |
| SWITCHING | | | | | |
| t_{gd} | Delay time | μs | 2.00 | $T_j=25\text{ }^\circ\text{C}; V_D=0.4 \cdot V_{DRM}; I_{TM}=I_{TAV};$ Gate pulse: $I_G=2\text{ A};$ $t_{GP}=50\text{ }\mu\text{s}; di_G/dt \geq 1\text{ A}/\mu\text{s}$ | |
| t_q | Turn-off time, max | μs | 125 | $dv_D/dt=50\text{ V}/\mu\text{s}; T_j=T_{j\text{ max}}; I_{TM}=200\text{ A};$ $di_R/dt=-10\text{ A}/\mu\text{s}; V_R=100\text{ V};$ $V_D=0.67 V_{DRM};$ | |
| Q_{rr} | Total recovered charge, max | μC | 720 | $T_j=T_{j\text{ max}}; I_{TM}=200\text{ A};$ | |
| t_{rr} | Reverse recovery time, max | μs | 16 | $di_R/dt=-10\text{ A}/\mu\text{s};$ | |
| I_{rrM} | Peak reverse recovery current, max | A | 90 | $V_R=100\text{ V}$ | |
| THERMAL | | | | | |
| R_{thjc} | Thermal resistance, junction to case | | | | |
| | per module | $^\circ\text{C}/\text{W}$ | 0.0900 | 180° half-sine wave, 50 Hz | |
| | per arm | $^\circ\text{C}/\text{W}$ | 0.1800 | | |
| | per module | $^\circ\text{C}/\text{W}$ | 0.0850 | DC | |
| per arm | $^\circ\text{C}/\text{W}$ | 0.1700 | | | |
| R_{thch} | Thermal resistance, case to heatsink | | | | |
| | per module | $^\circ\text{C}/\text{W}$ | 0.0300 | | |
| | per arm | $^\circ\text{C}/\text{W}$ | 0.0600 | | |
| INSULATION | | | | | |
| V_{ISOL} | Insulation test voltage | kV | 3.00 | Sine wave, 50 Hz; RMS | t=1 min |
| | | | 3.60 | | t=1 sec |
| MECHANICAL | | | | | |
| M_1 | Mounting torque (M6) ¹⁾ | Nm | 6.00 | Tolerance $\pm 15\%$ | |
| M_2 | Terminal connection torque (M6) ¹⁾ | Nm | 6.00 | Tolerance $\pm 15\%$ | |
| w | Weight | g | 320 | | |

| PART NUMBERING GUIDE | | | | | | NOTES | | | | |
|--|---|---|-----|---|----|-------|---|---|---|----------------------------------|
| MT | 3 | - | 201 | - | 18 | - | F | - | N | |
| 1 | 2 | | 3 | | 4 | | 5 | | 6 | |
| 1. Thyristor module (MT) Thyristor – Diode module (MT/D) Diode – Thyristor module (MD/T) 2. Circuit Schematic 3. Average On-state Current, A 4. Voltage Code 5. Package Type (M.F) 6. Ambient Conditions: N – Normal | | | | | | | | | | |
| | | | | | | | | | | 1) The screws must be lubricated |

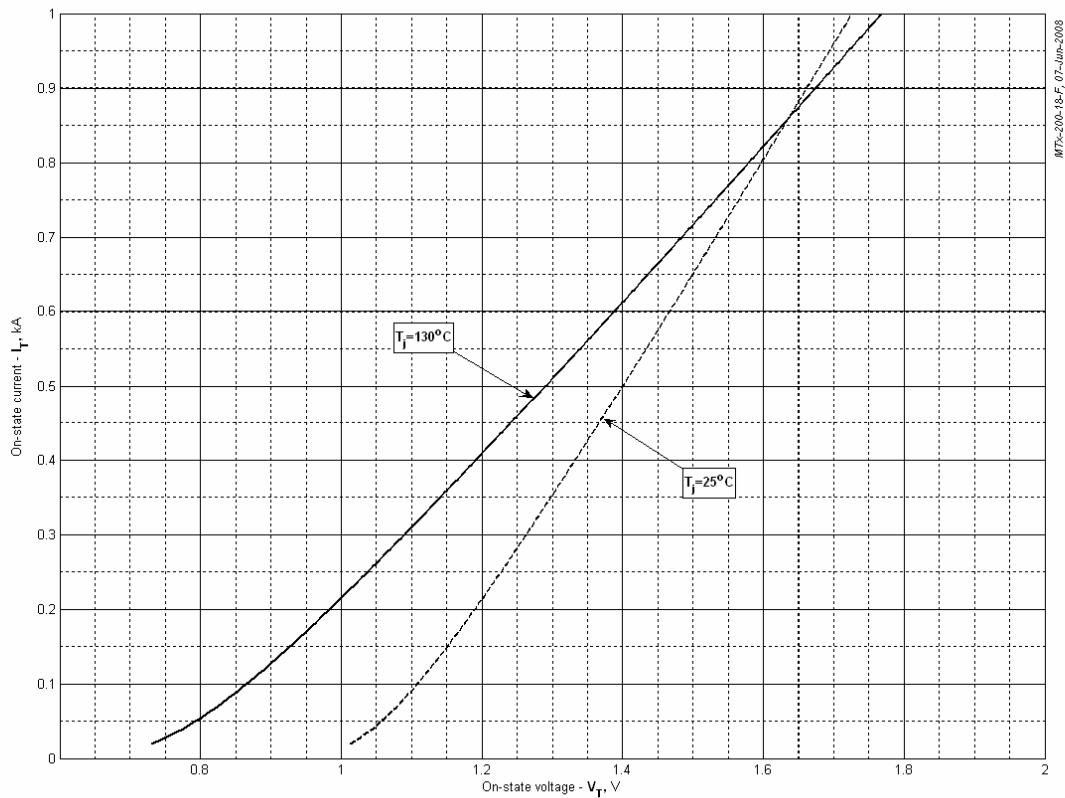

Fig 1 – On-state characteristics of Limit device

Analytical function for On-state characteristic:

$$V_T = A + B \cdot i_T + C \cdot \ln(i_T + 1) + D \cdot \sqrt{i_T}$$

| | Coefficients for max curves | |
|----------|-----------------------------|-------------------------|
| | $T_j = 25^\circ\text{C}$ | $T_j = T_{j\text{max}}$ |
| A | 0.956132 | 0.652386 |
| B | 0.635427 | 0.934386 |
| C | -0.365344 | -0.494072 |
| D | 0.388161 | 0.524930 |

On-state characteristic model (see Fig. 1)

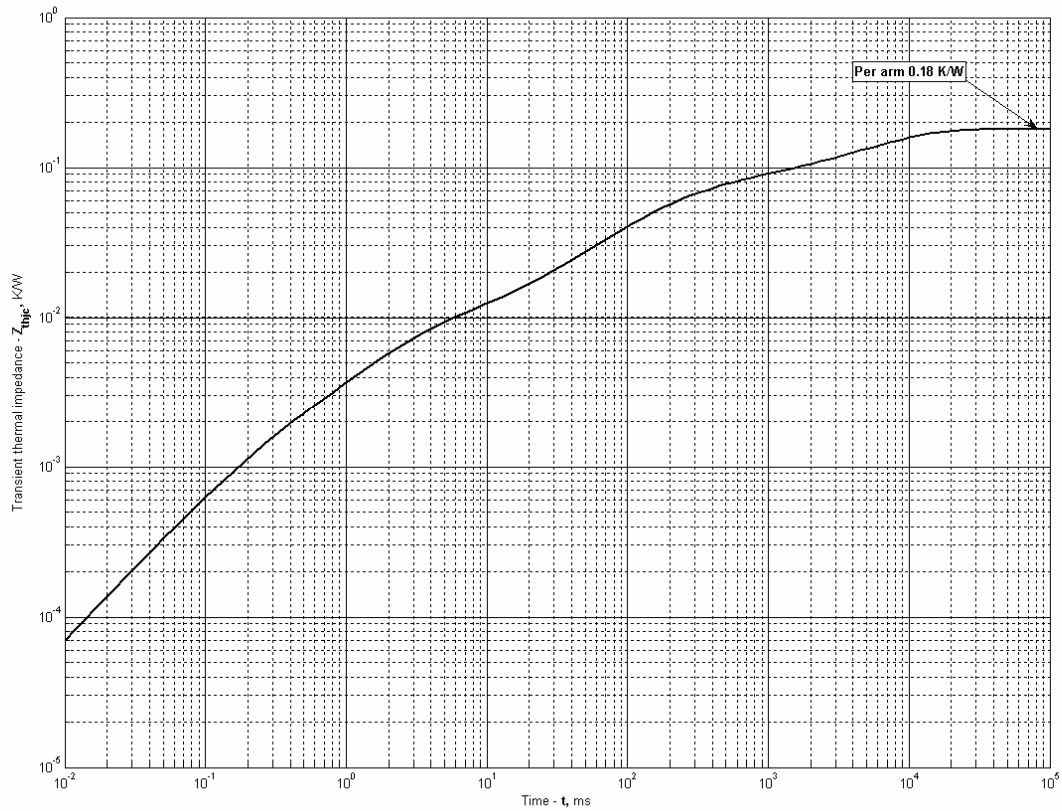

Fig 2 – Transient thermal impedance

Analytical function for Transient thermal impedance junction to case Z_{thjc} for DC:

$$Z_{thjc} = \sum_{i=1}^n R_i \left(1 - e^{-\frac{t}{\tau_i}} \right)$$

Where $i = 1$ to n , n is the number of terms in the series.

t = Duration of heating pulse in seconds.

Z_{thjc} = Thermal resistance at time t .

R_i = Amplitude of p_{th} term.

τ_i = Time constant of r_{th} term.

| i | 1 | 2 | 3 | 4 | 5 | 6 |
|------------------------------|-----------|----------|----------|----------|----------|----------|
| R_i K/W | 0.0007653 | 0.00703 | 0.01629 | 0.04126 | 0.01513 | 0.09951 |
| τ_i S | 0.0002111 | 0.002366 | 0.06905 | 0.1909 | 0.6646 | 6.64 |

Transient thermal impedance junction to case Z_{thjc} model (see Fig. 2)

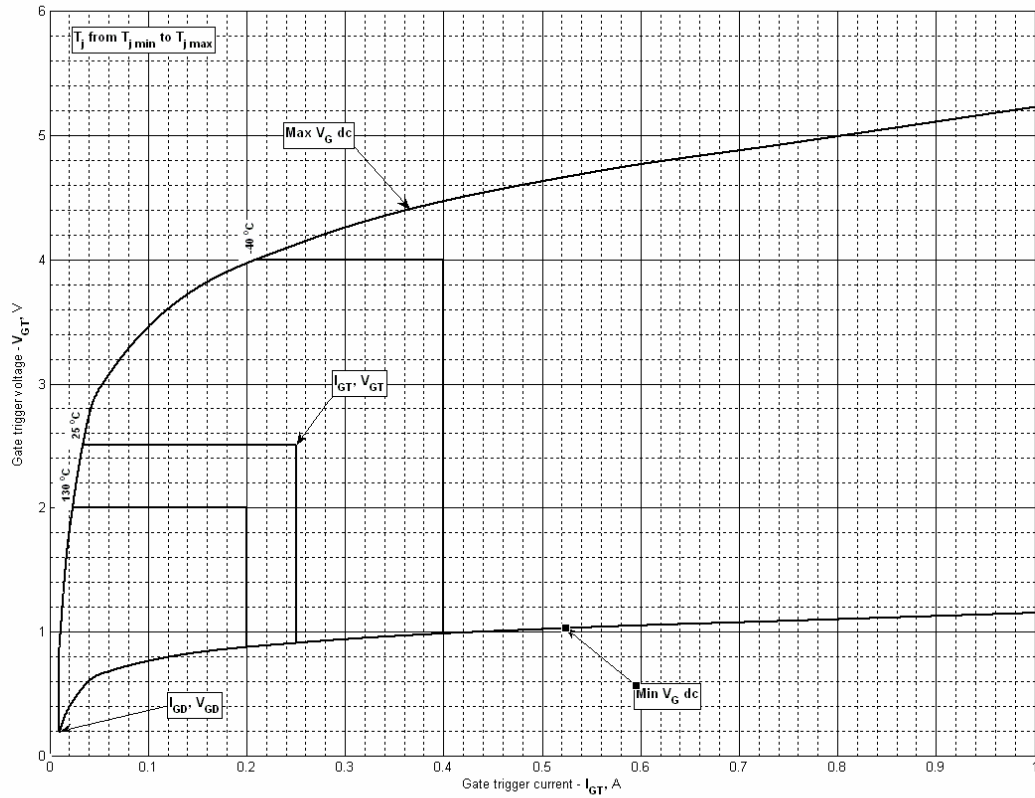

Fig 3 – Gate characteristics – Trigger limits

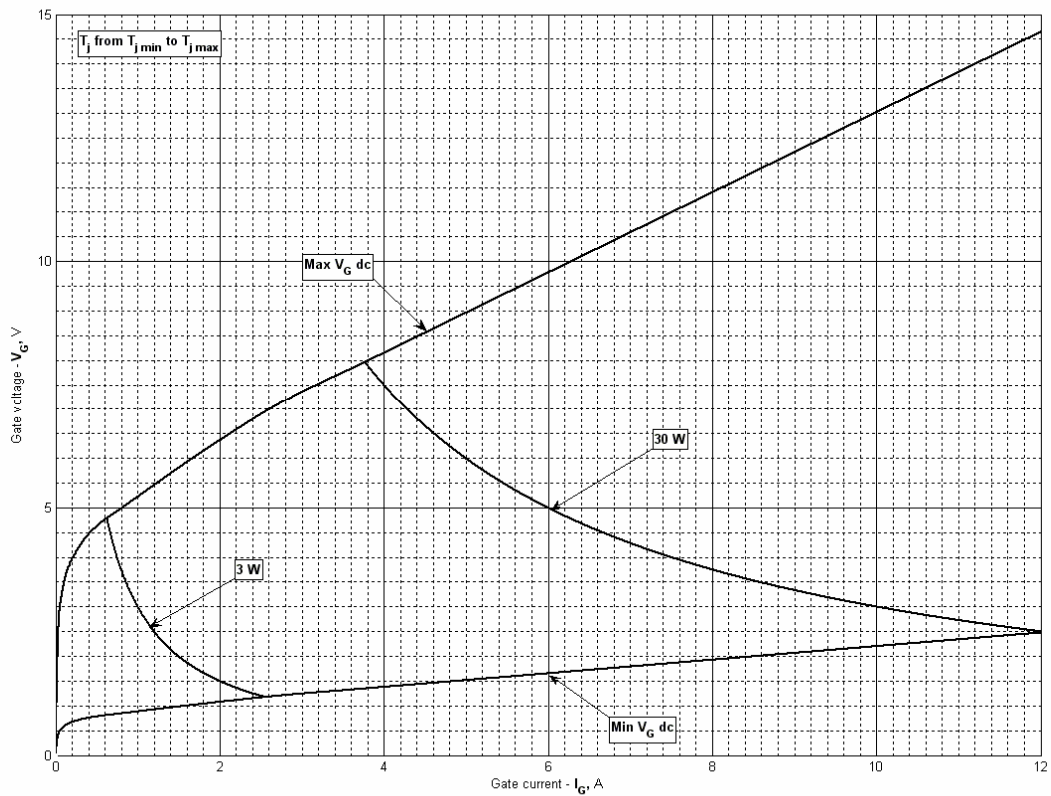

Fig 4 - Gate characteristics – Power curves

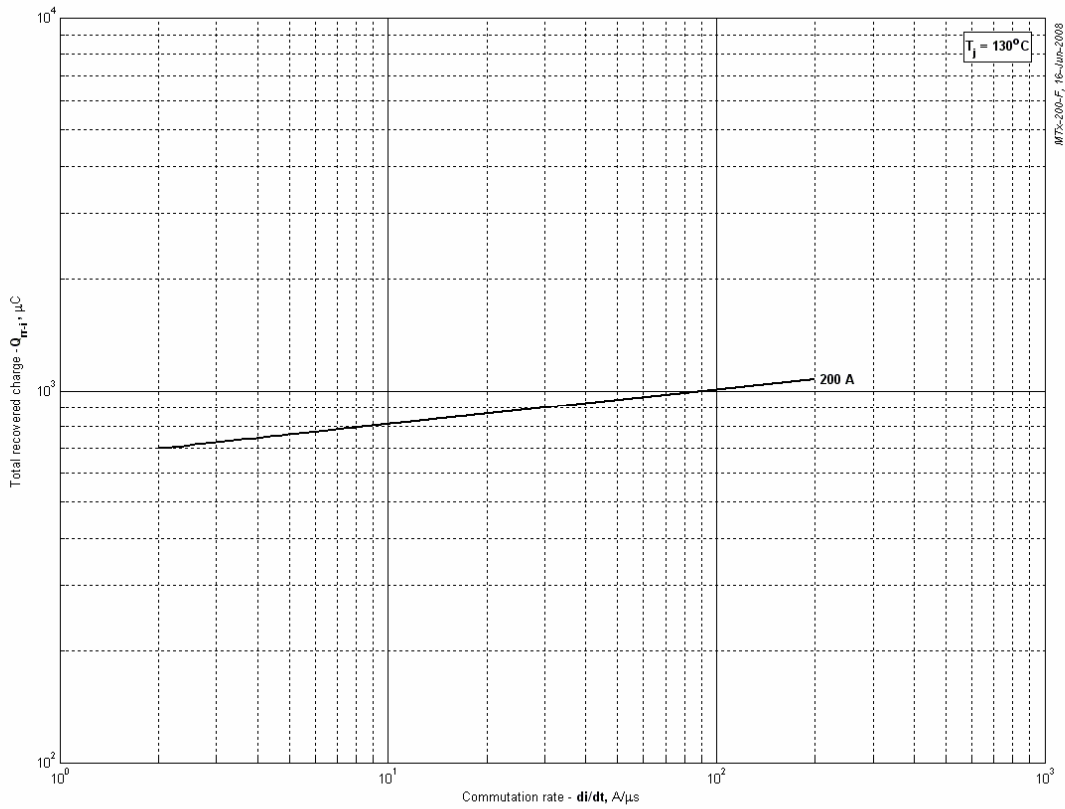

Fig 5 - Total recovered charge, Q_{rr-i} (integral)

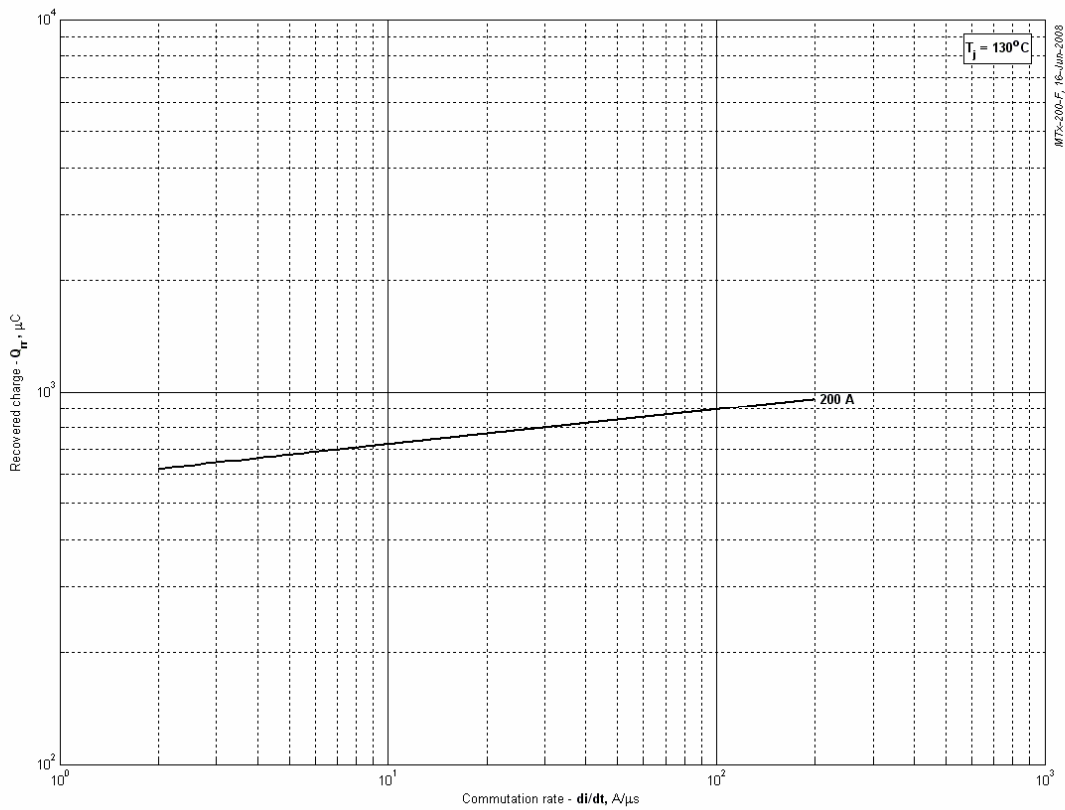

Fig 6 - Recovered charge, Q_{rr} (linear)

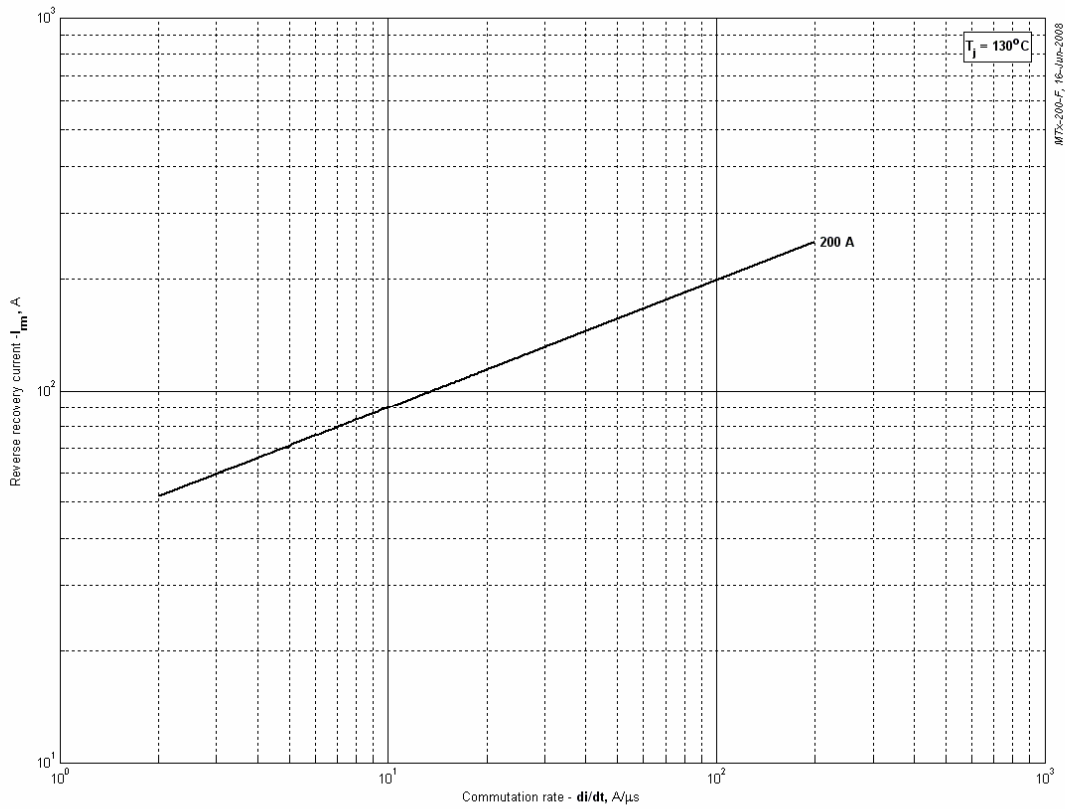

Fig 7 - Peak reverse recovery current, I_{rm}

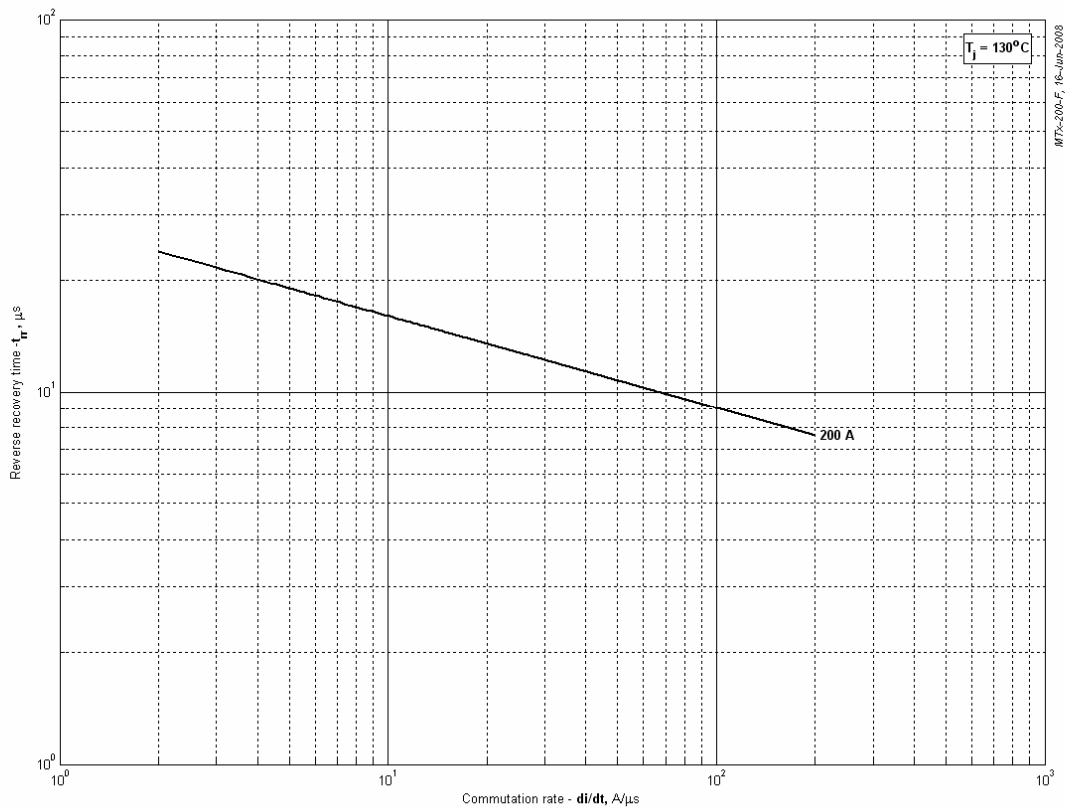

Fig 8 - Recovery time, t_{rr} (50% chord)

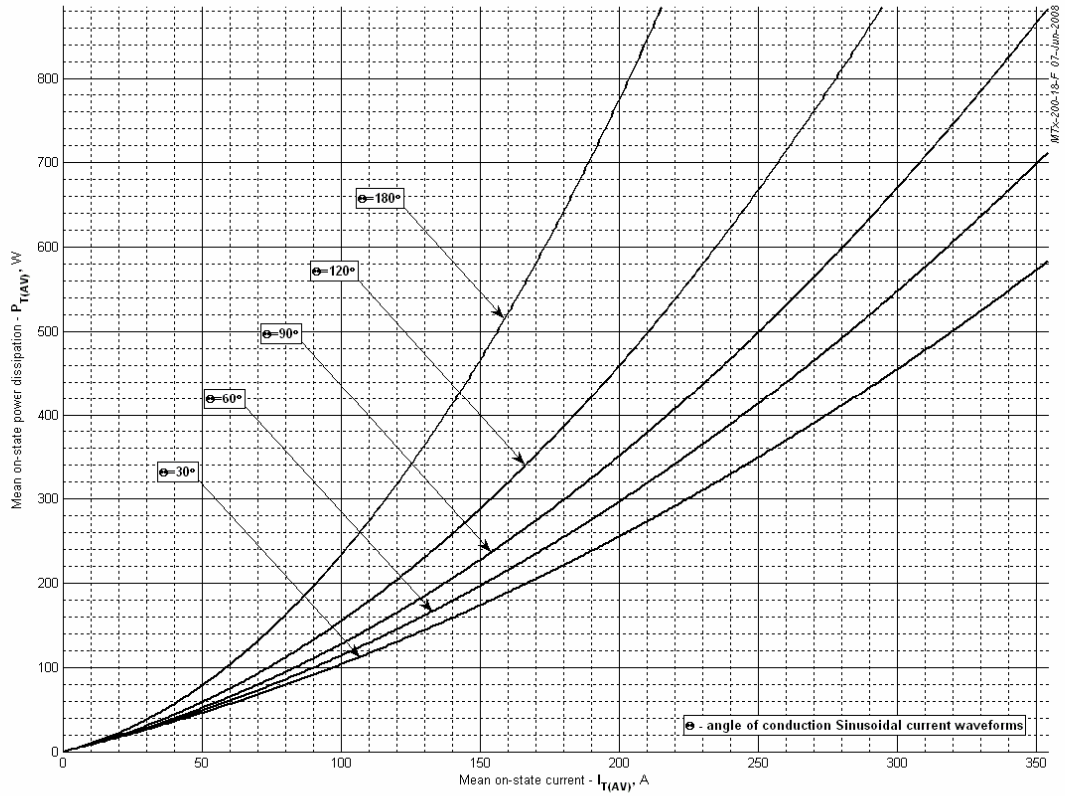

Fig 9 – On-state power loss (sinusoidal current waveforms)

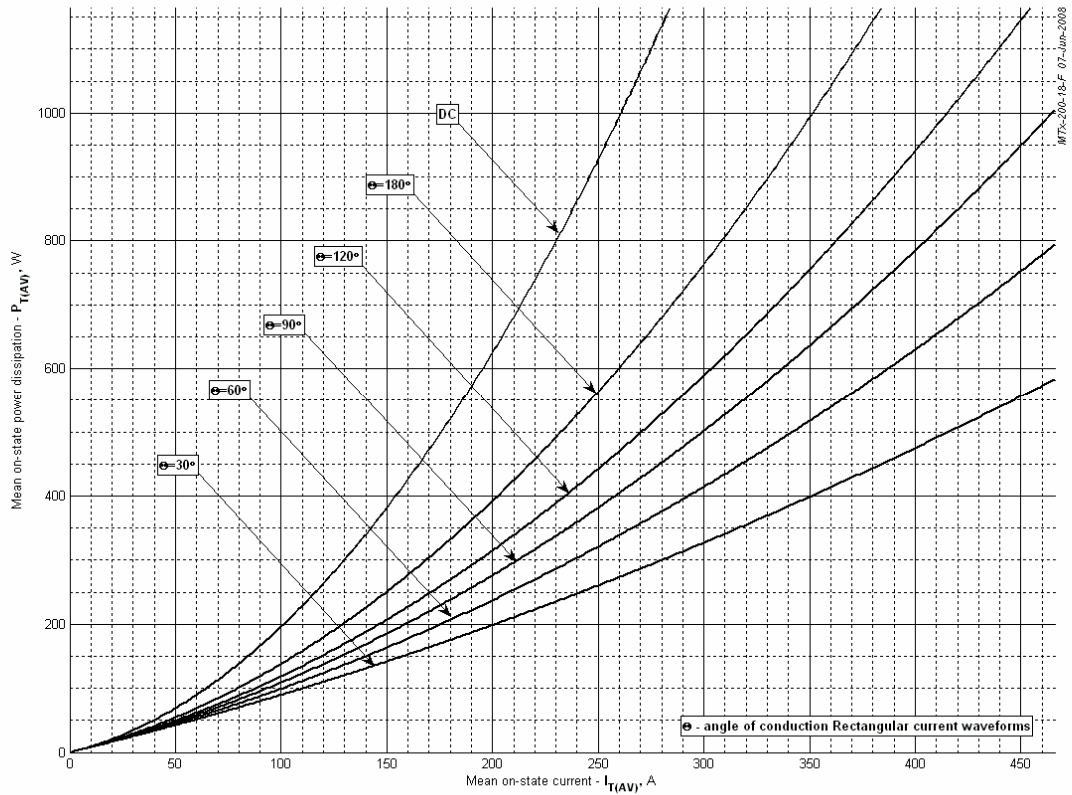

Fig 10 - On-state power loss (rectangular current waveforms)

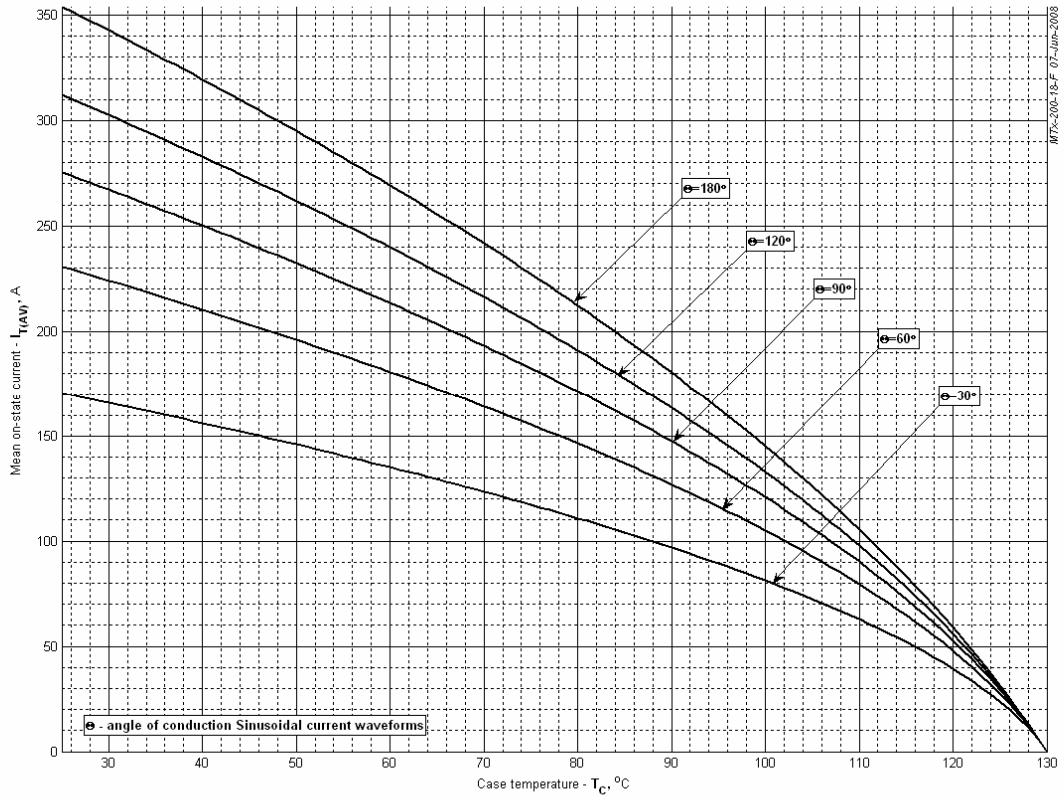

Fig 11 – Maximum case temperature (sinusoidal current waveforms)

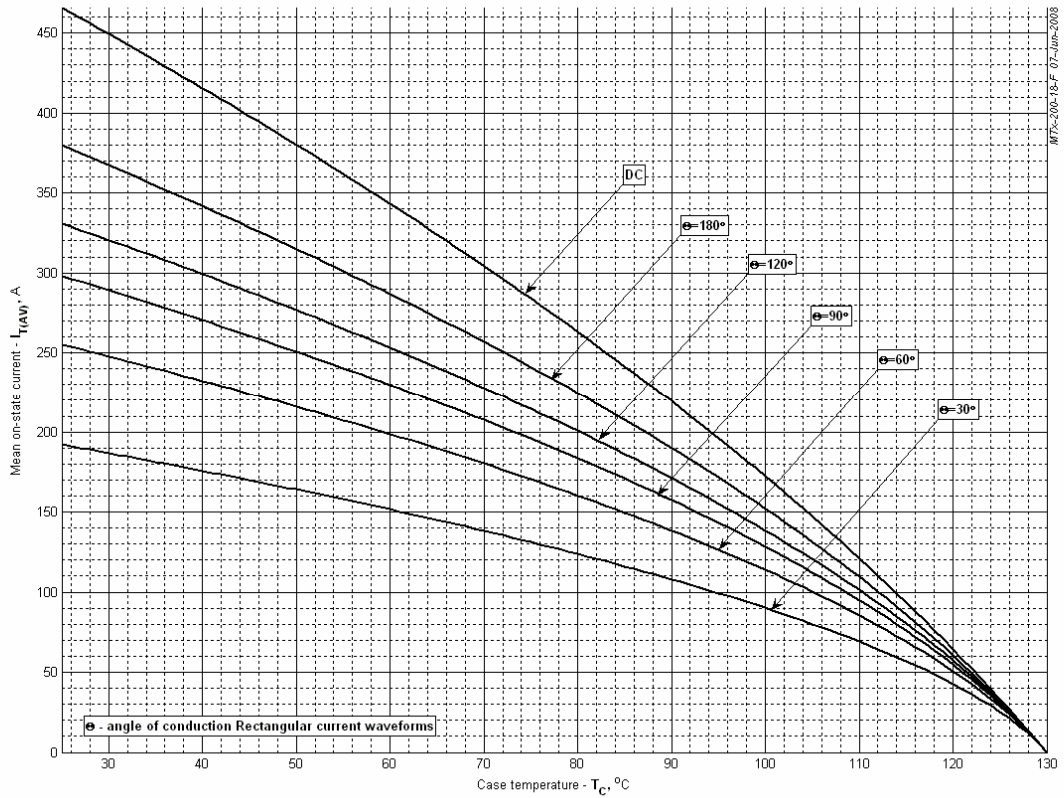

Fig 12 - Maximum case temperature (rectangular current waveforms)

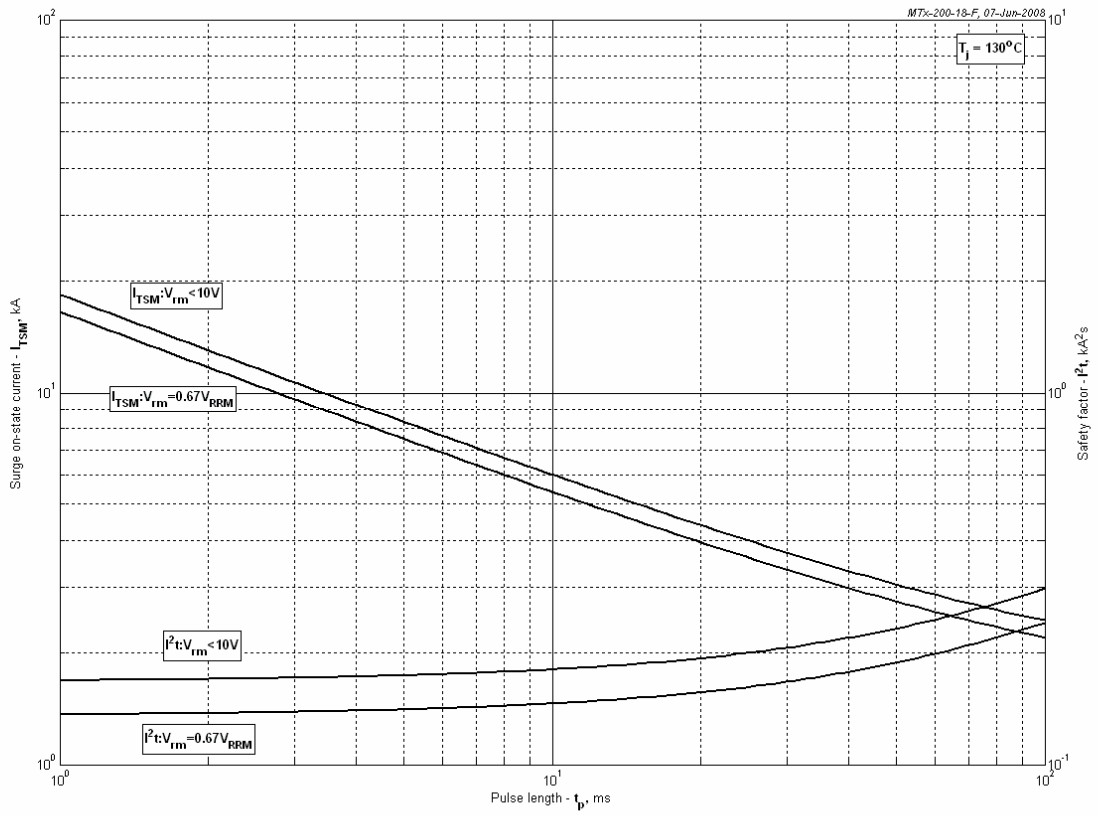

Fig 13 – Maximum surge and I^2t ratings

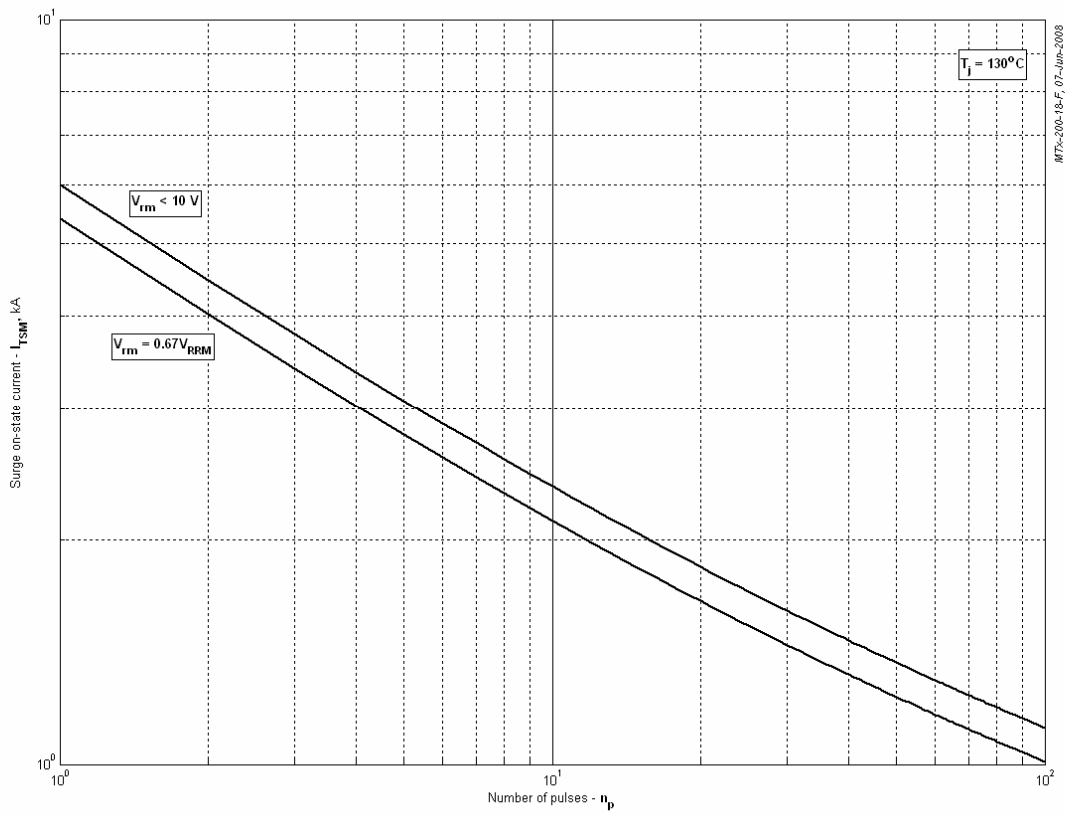

Fig 14 - Maximum surge ratings