

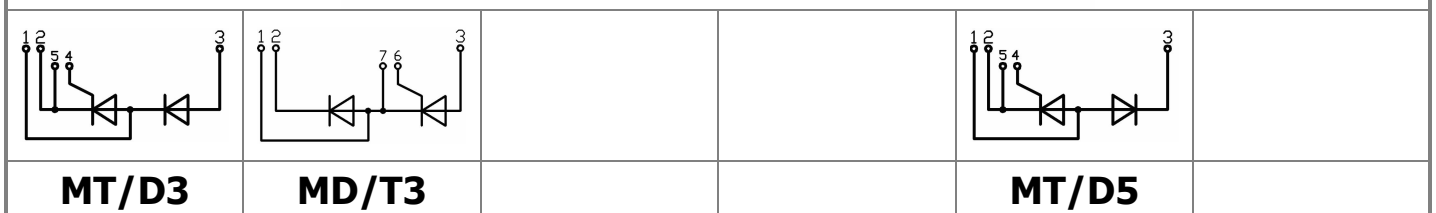

Electrically isolated base plate
Industrial standard package
Simplified mechanical design, rapid assembly
Pressure contact

Double Thyristor Module
For Phase Control
MTx-165-22-F

Mean on-state current	I_{TAV}	165 A
Repetitive peak off-state voltage	V_{DRM}	2000 ÷ 2200 V
Repetitive peak reverse voltage	V_{RRM}	
Turn-off time	t_q	125 μ s
V_{DRM}, V_{RRM}, V	2000	2200
Voltage code	20	22
$T_{j}, ^\circ C$	- 40 ÷ 125	

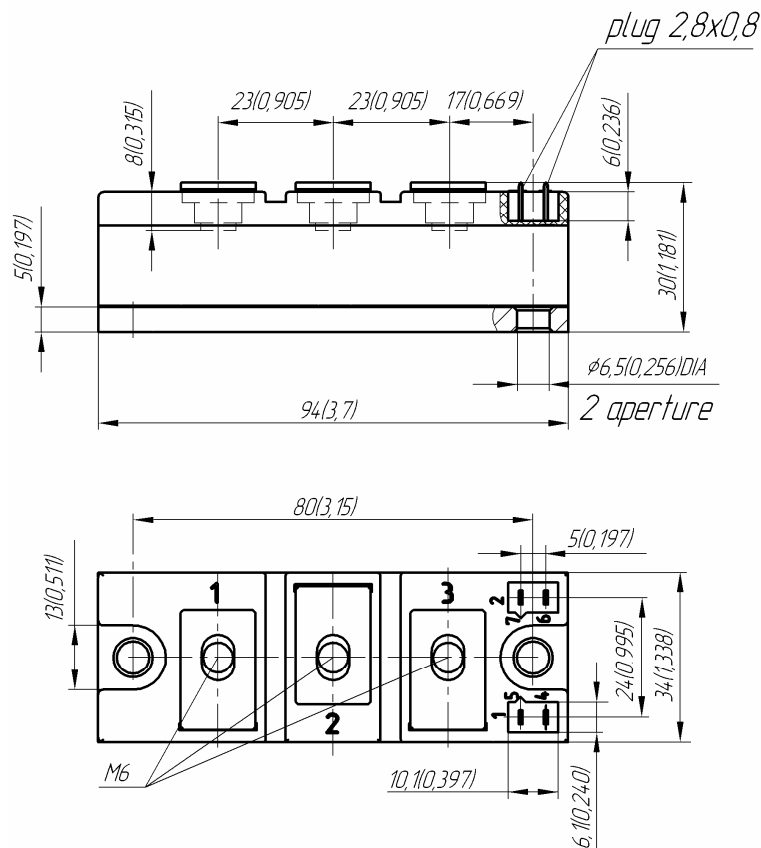
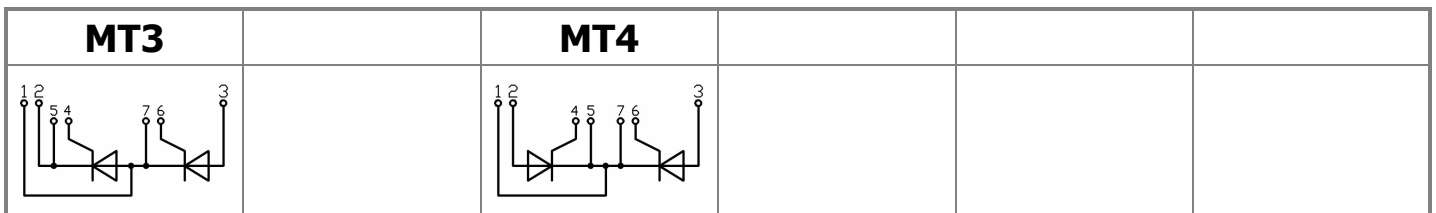

MAXIMUM ALLOWABLE RATINGS

Symbols and parameters		Units	Values	Test conditions
ON-STATE				
I_{TAV}	Mean on-state current	A	165	$T_c = 85\text{ }^\circ\text{C}$; 180° half-sine wave; 50 Hz
I_{TRMS}	RMS on-state current	A	259	
I_{TSM}	Surge on-state current	kA	4.7 5.5	$T_j = T_{j\max}$ $T_j = 25\text{ }^\circ\text{C}$ 180° half-sine wave; 50 Hz ($t_p = 10\text{ ms}$); single pulse; $V_D = V_R = 0\text{ V}$; Gate pulse: $I_G = 2\text{ A}$; $t_{GP} = 50\text{ }\mu\text{s}$; $di_G/dt \geq 1\text{ A}/\mu\text{s}$
			5.0 5.8	$T_j = T_{j\max}$ $T_j = 25\text{ }^\circ\text{C}$ 180° half-sine wave; 60 Hz ($t_p = 8.3\text{ ms}$); single pulse; $V_D = V_R = 0\text{ V}$; Gate pulse: $I_G = 2\text{ A}$; $t_{GP} = 50\text{ }\mu\text{s}$; $di_G/dt \geq 1\text{ A}/\mu\text{s}$
I^2t	Safety factor	$A^2s \cdot 10^3$	110 145	$T_j = T_{j\max}$ $T_j = 25\text{ }^\circ\text{C}$ 180° half-sine wave; 50 Hz ($t_p = 10\text{ ms}$); single pulse; $V_D = V_R = 0\text{ V}$; Gate pulse: $I_G = 2\text{ A}$; $t_{GP} = 50\text{ }\mu\text{s}$; $di_G/dt \geq 1\text{ A}/\mu\text{s}$
			100 135	$T_j = T_{j\max}$ $T_j = 25\text{ }^\circ\text{C}$ 180° half-sine wave; 60 Hz ($t_p = 8.3\text{ ms}$); single pulse; $V_D = V_R = 0\text{ V}$; Gate pulse: $I_G = 2\text{ A}$; $t_{GP} = 50\text{ }\mu\text{s}$; $di_G/dt \geq 1\text{ A}/\mu\text{s}$
BLOCKING				
V_{DRM}, V_{RRM}	Repetitive peak off-state and Repetitive peak reverse voltages	V	2000÷2200	$T_{j\min} < T_j < T_{j\max}$; 180° half-sine wave; 50 Hz; Gate open
V_{DSM}, V_{RSM}	Non-repetitive peak off-state and Non-repetitive peak reverse voltages	V	2100÷2300	$T_{j\min} < T_j < T_{j\max}$; 180° half-sine wave; 50 Hz; single pulse; Gate open
V_D, V_R	Direct off-state and Direct reverse voltages	V	$0.75 \cdot V_{DRM}$ $0.75 \cdot V_{RRM}$	$T_j = T_{j\max}$; Gate open
TRIGGERING				
I_{FGM}	Peak forward gate current	A	5	$T_j = T_{j\max}$
V_{RGM}	Peak reverse gate voltage	V	5	
P_G	Gate power dissipation	W	3	$T_j = T_{j\max}$ for DC gate current
SWITCHING				
$(di_T/dt)_{crit}$	Critical rate of rise of on-state current non-repetitive (f=1 Hz)	$A/\mu\text{s}$	500	$T_j = T_{j\max}$; $V_D = 0.67 \cdot V_{DRM}$; $I_{TM} = 2 I_{TAV}$; Gate pulse: $I_G = 2\text{ A}$; $t_{GP} = 50\text{ }\mu\text{s}$; $di_G/dt \geq 1\text{ A}/\mu\text{s}$
THERMAL				
T_{stg}	Storage temperature	$^\circ\text{C}$	-40 ÷ 125	
T_j	Operating junction temperature	$^\circ\text{C}$	-40 ÷ 125	
MECHANICAL				
a	Acceleration under vibration	m/s^2	50	

CHARACTERISTICS

Symbols and parameters		Units	Values	Conditions	
ON-STATE					
V_{TM}	Peak on-state voltage, max	V	1.50	$T_j=25\text{ }^\circ\text{C}; I_{TM}=500\text{ A}$	
$V_{T(TO)}$	On-state threshold voltage, max	V	0.80	$T_j=T_{j\text{ max}}$	
r_T	On-state slope resistance, max	m Ω	1.350	$0.5\pi I_{TAV} < I_T < 1.5\pi I_{TAV}$	
I_L	Latching current, max	mA	500	$T_j=25\text{ }^\circ\text{C}; V_D=12\text{ V};$ Gate pulse: $I_G=2\text{ A};$ $t_{GP}=50\text{ }\mu\text{s}; di_G/dt \geq 1\text{ A}/\mu\text{s}$	
I_H	Holding current, max	mA	250	$T_j=25\text{ }^\circ\text{C};$ $V_D=12\text{ V};$ Gate open	
BLOCKING					
I_{DRM}, I_{RRM}	Repetitive peak off-state and Repetitive peak reverse currents, max	mA	30	$T_j=T_{j\text{ max}};$ $V_D=V_{DRM}; V_R=V_{RRM}$	
$(dv_D/dt)_{crit}$	Critical rate of rise of off-state voltage, min	V/ μs	1000	$T_j=T_{j\text{ max}};$ $V_D=0.67\cdot V_{DRM};$ Gate open	
TRIGGERING					
V_{GT}	Gate trigger direct voltage, max	V	4.00 2.50 2.00	$T_j=T_{j\text{ min}}$ $T_j=25\text{ }^\circ\text{C}$ $T_j=T_{j\text{ max}}$	$V_D=12\text{ V}; I_D=3\text{ A};$ Direct gate current
I_{GT}	Gate trigger direct current, max	mA	400 250 200	$T_j=T_{j\text{ min}}$ $T_j=25\text{ }^\circ\text{C}$ $T_j=T_{j\text{ max}}$	
V_{GD}	Gate non-trigger direct voltage, min	V	0.25	$T_j=T_{j\text{ max}};$ $V_D=0.67\cdot V_{DRM};$	
I_{GD}	Gate non-trigger direct current, min	mA	10.00	Direct gate current	
SWITCHING					
t_{gd}	Delay time	μs	2.50	$T_j=25\text{ }^\circ\text{C}; V_D=0.4\cdot V_{DRM}; I_{TM}=I_{TAV};$ Gate pulse: $I_G=2\text{ A};$ $t_{GP}=50\text{ }\mu\text{s}; di_G/dt \geq 1\text{ A}/\mu\text{s}$	
t_q	Turn-off time, max	μs	125	$dv_D/dt=50\text{ V}/\mu\text{s}; T_j=T_{j\text{ max}}; I_{TM}=200\text{ A};$ $di_R/dt=-10\text{ A}/\mu\text{s}; V_R=100\text{ V};$ $V_D=0.67\cdot V_{DRM};$	
Q_{rr}	Total recovered charge, max	μC	855	$T_j=T_{j\text{ max}}; I_{TM}=200\text{ A};$	
t_{rr}	Reverse recovery time, max	μs	18	$di_R/dt=-10\text{ A}/\mu\text{s};$	
I_{rrM}	Peak reverse recovery current, max	A	95	$V_R=100\text{ V}$	
THERMAL					
R_{thjc}	Thermal resistance, junction to case				
	per module	$^\circ\text{C}/\text{W}$	0.0900	180° half-sine wave, 50 Hz	
	per arm	$^\circ\text{C}/\text{W}$	0.1800		
	per module	$^\circ\text{C}/\text{W}$	0.0850	DC	
per arm	$^\circ\text{C}/\text{W}$	0.1700			
R_{thch}	Thermal resistance, case to heatsink				
	per module	$^\circ\text{C}/\text{W}$	0.0300		
	per arm	$^\circ\text{C}/\text{W}$	0.0600		
INSULATION					
V_{ISOL}	Insulation test voltage	kV	3.00	Sine wave, 50 Hz; RMS	t=1 min
			3.60		t=1 sec
MECHANICAL					
M_1	Mounting torque (M6) ¹⁾	Nm	6.00	Tolerance $\pm 15\%$	
M_2	Terminal connection torque (M6) ¹⁾	Nm	6.00	Tolerance $\pm 15\%$	
w	Weight	g	320		

PART NUMBERING GUIDE						NOTES				
MT	3	-	165	-	22	-	F	-	N	
1	2		3		4		5		6	
1. Thyristor module (MT) Thyristor – Diode module (MT/D) Diode – Thyristor module (MD/T) 2. Circuit Schematic 3. Average On-state Current, A 4. Voltage Code 5. Package Type (M.F) 6. Ambient Conditions: N – Normal										
										1) The screws must be lubricated

The information contained herein is confidential and protected by Copyright.
 In the interest of product improvement, Proton-Electrotex reserves the right to change data sheet without notice.

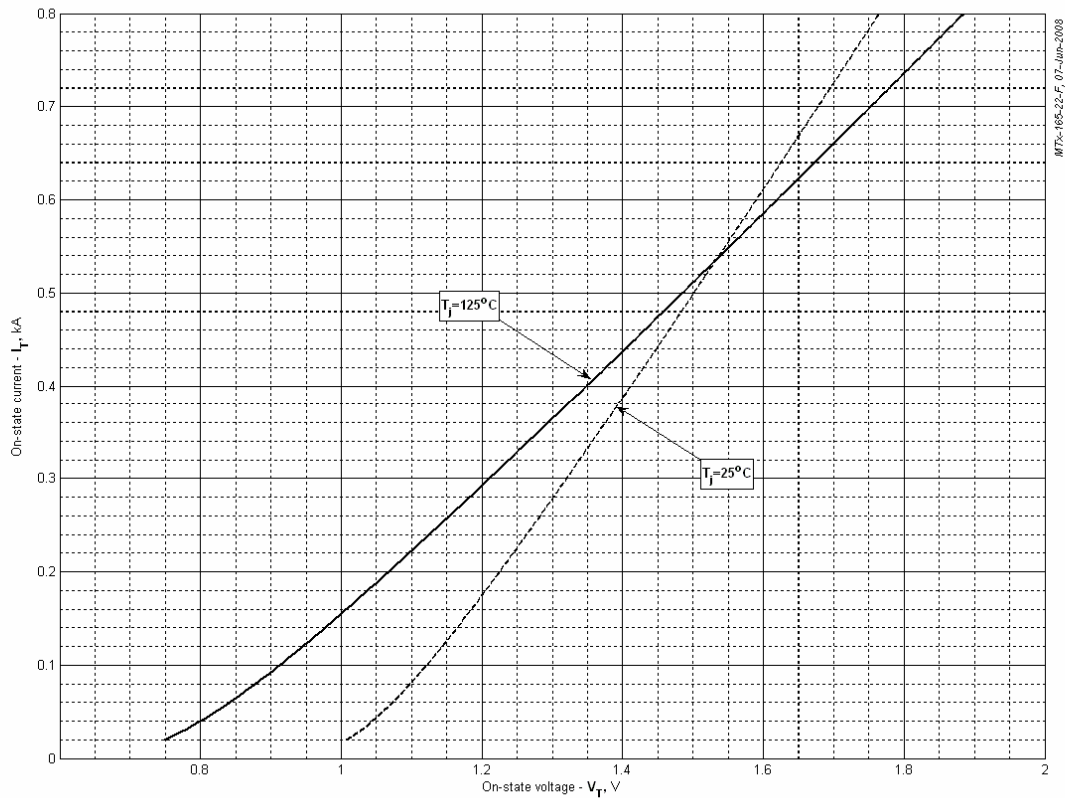

MTX-165-22-F, 07-Jun-2008

Fig 1 – On-state characteristics of Limit device

Analytical function for On-state characteristic:

$$V_T = A + B \cdot i_T + C \cdot \ln(i_T + 1) + D \cdot \sqrt{i_T}$$

	Coefficients for max curves	
	$T_j = 25^\circ\text{C}$	$T_j = T_{j\text{max}}$
A	0.943585	0.659211
B	0.891706	1.352412
C	-0.442302	-0.590725
D	0.411509	0.549600

On-state characteristic model (see Fig. 1)

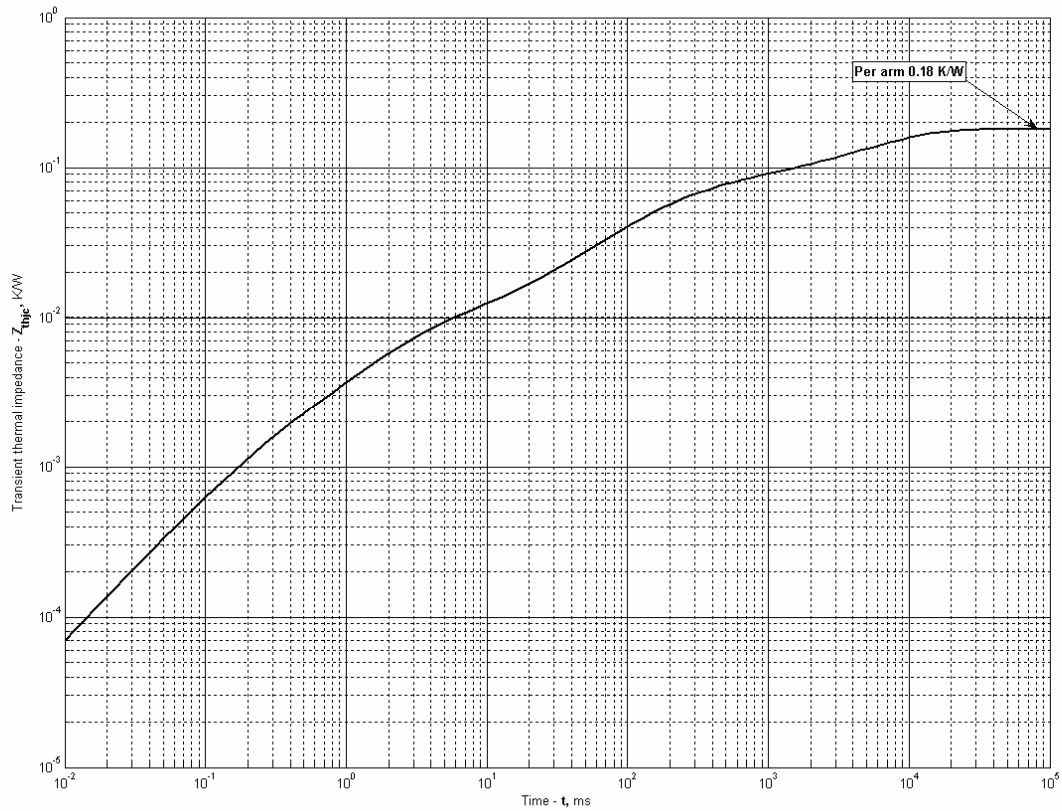

Fig 2 – Transient thermal impedance

Analytical function for Transient thermal impedance junction to case Z_{thjc} for DC:

$$Z_{thjc} = \sum_{i=1}^n R_i \left(1 - e^{-\frac{t}{\tau_i}} \right)$$

Where $i = 1$ to n , n is the number of terms in the series.

t = Duration of heating pulse in seconds.

Z_{thjc} = Thermal resistance at time t .

R_i = Amplitude of p_{th} term.

τ_i = Time constant of r_{th} term.

i	1	2	3	4	5	6
R_i K/W	0.0007653	0.00703	0.01629	0.04126	0.01513	0.09951
τ_i s	0.0002111	0.002366	0.06905	0.1909	0.6646	6.64

Transient thermal impedance junction to case Z_{thjc} model (see Fig. 2)

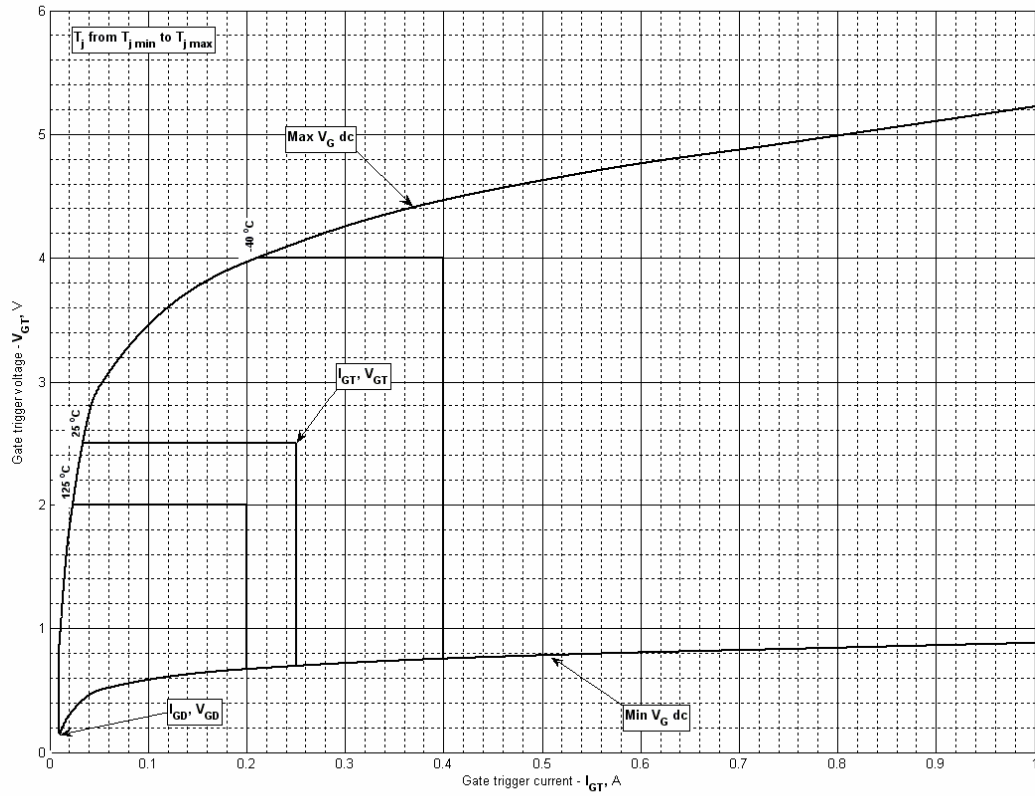

Fig 3 – Gate characteristics – Trigger limits

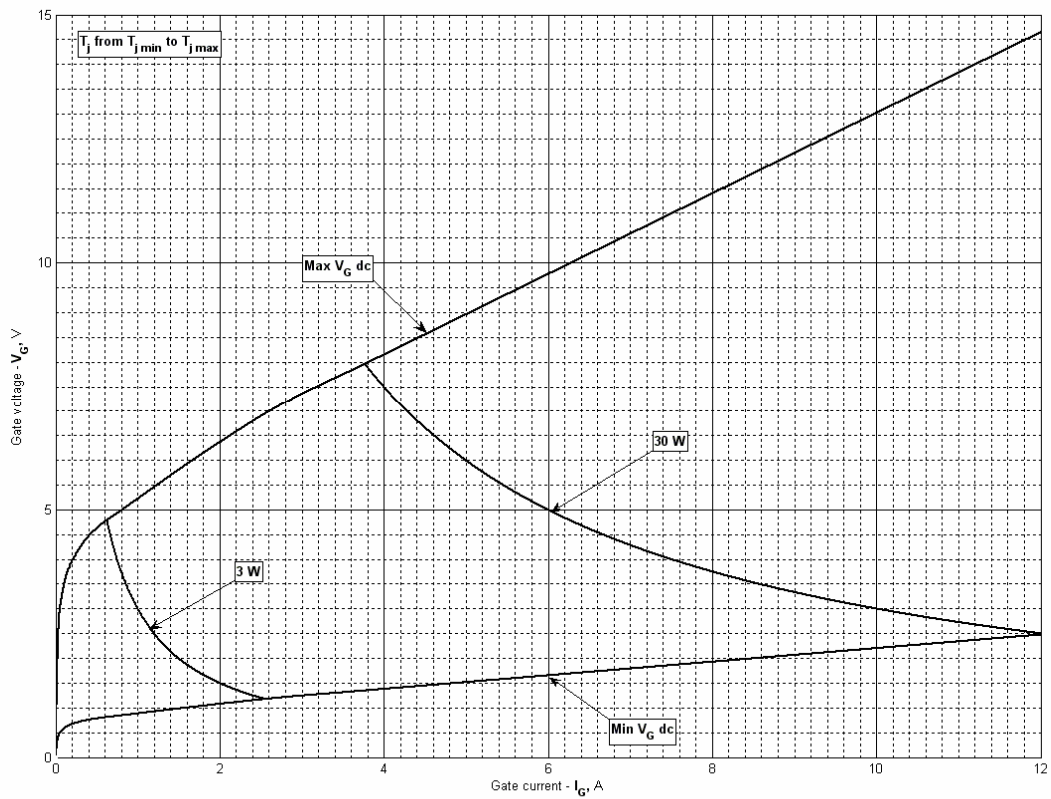

Fig 4 - Gate characteristics – Power curves

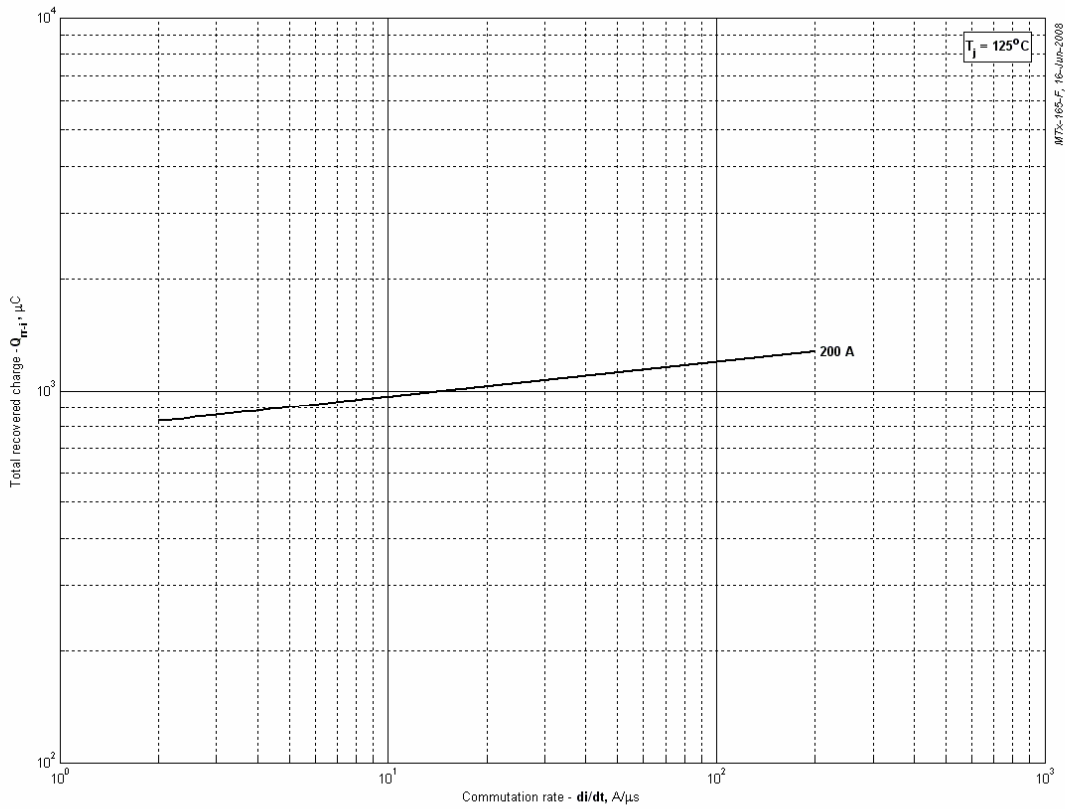

Fig 5 - Total recovered charge, Q_{rr-i} (integral)

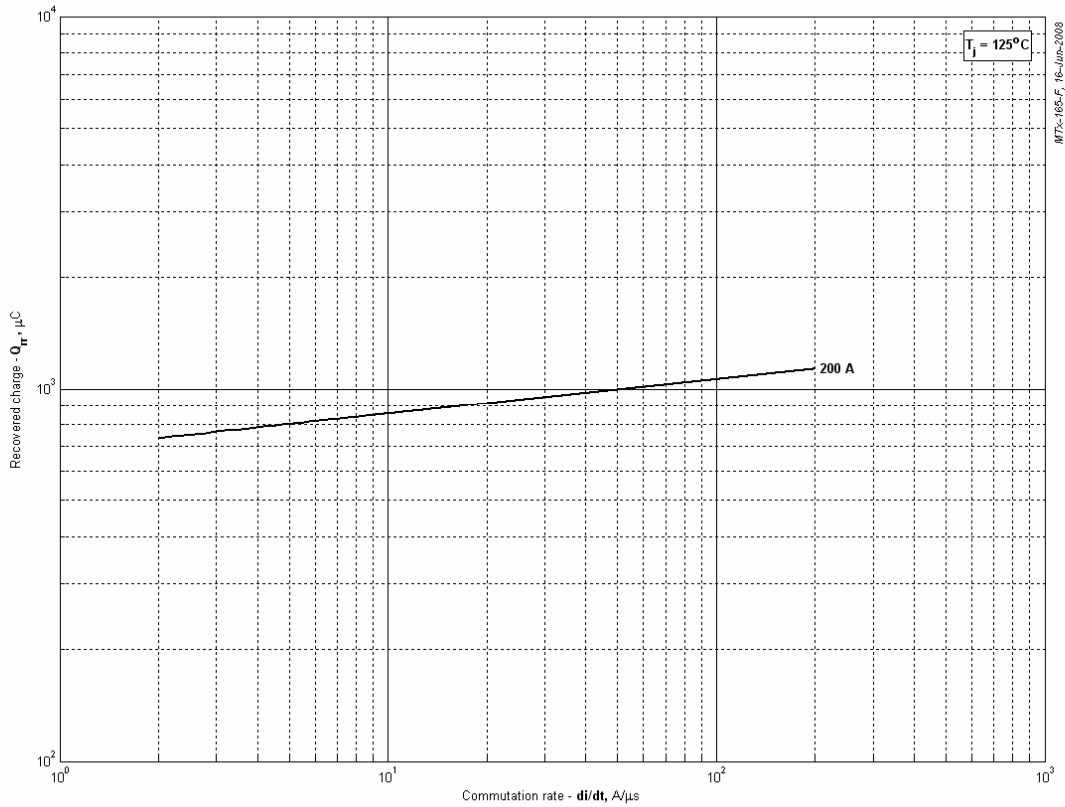

Fig 6 - Recovered charge, Q_{rr} (linear)

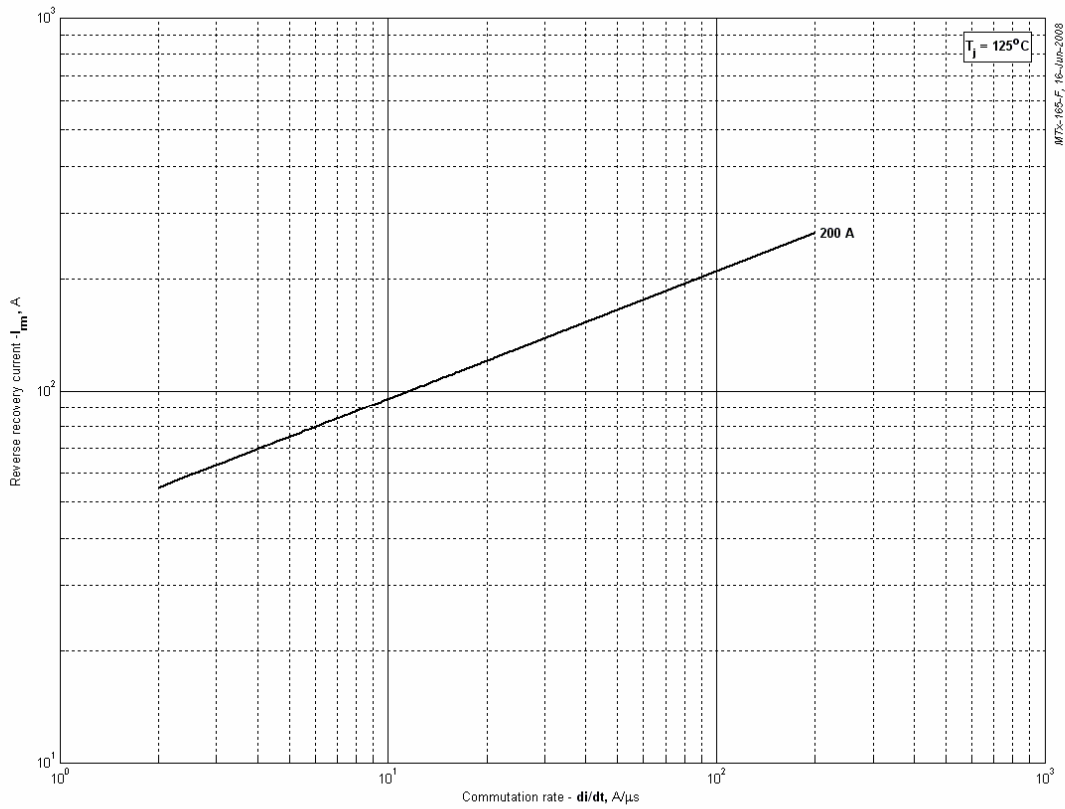

Fig 7 - Peak reverse recovery current, I_{rm}

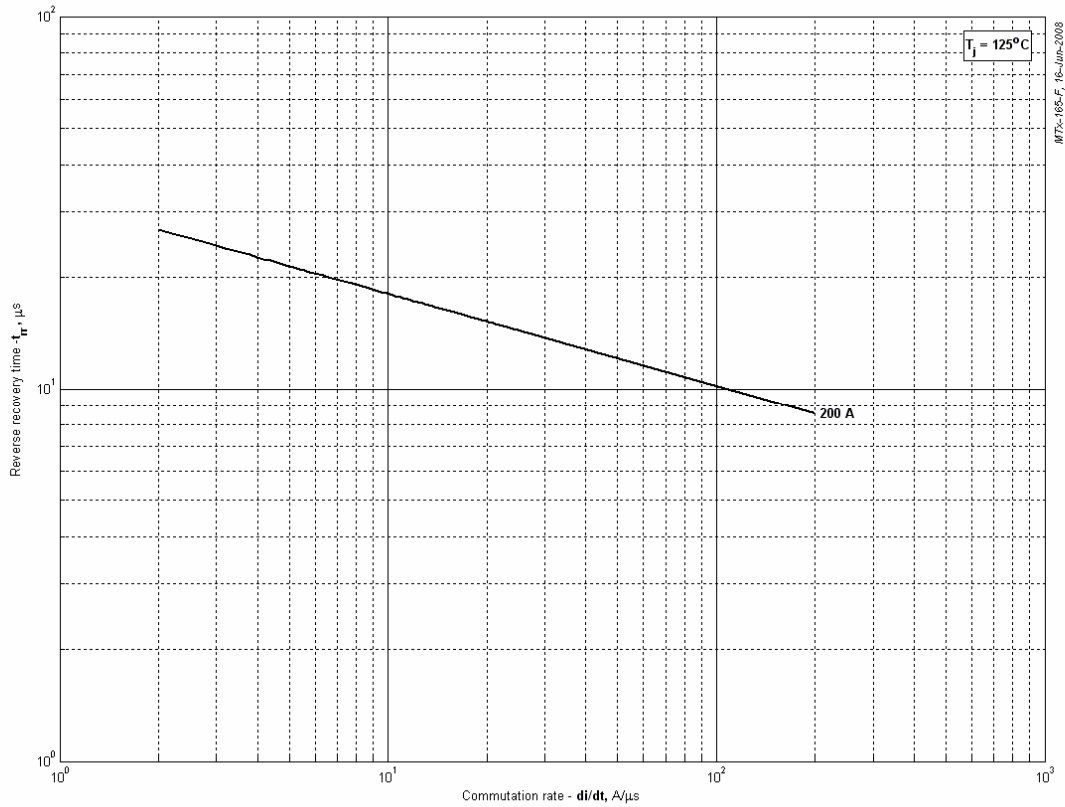

Fig 8 - Recovery time, t_{rr} (50% chord)

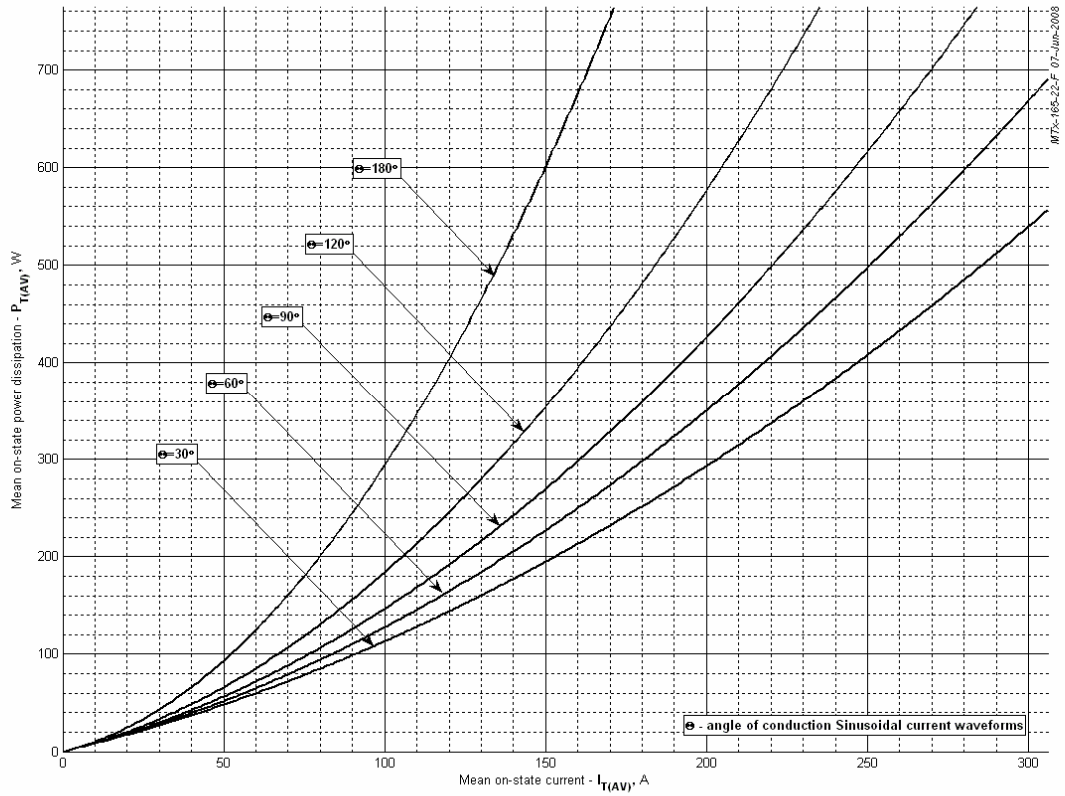

Fig 9 – On-state power loss (sinusoidal current waveforms)

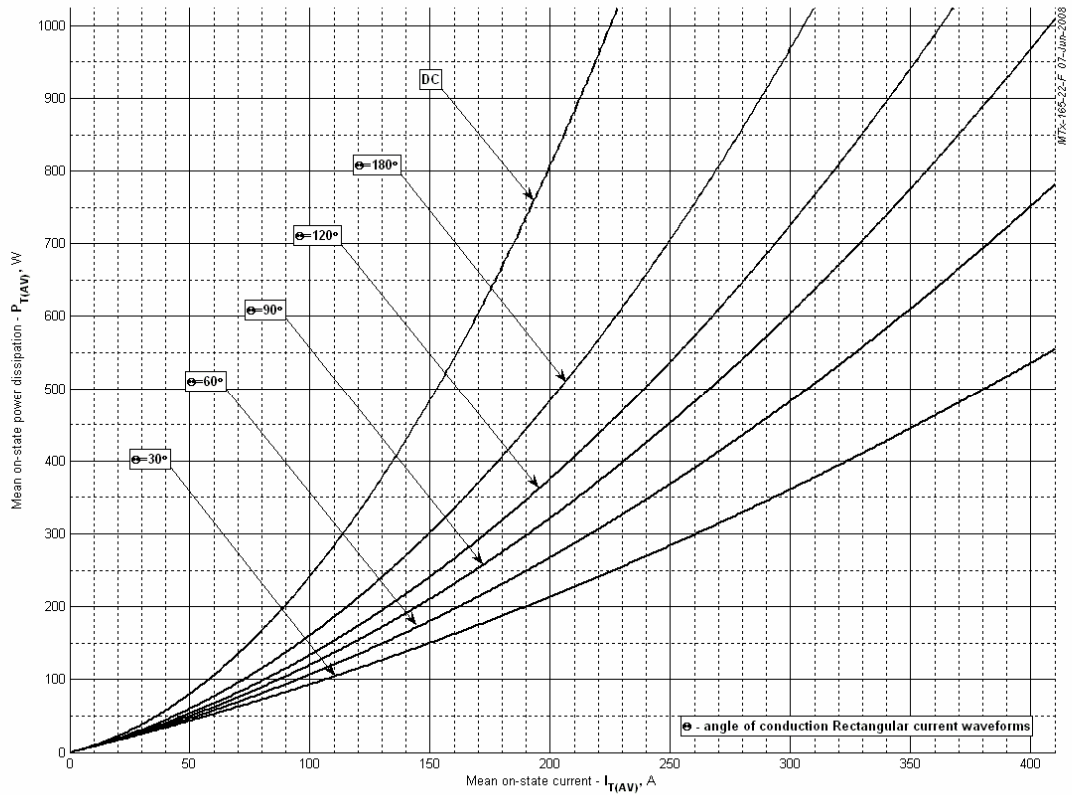
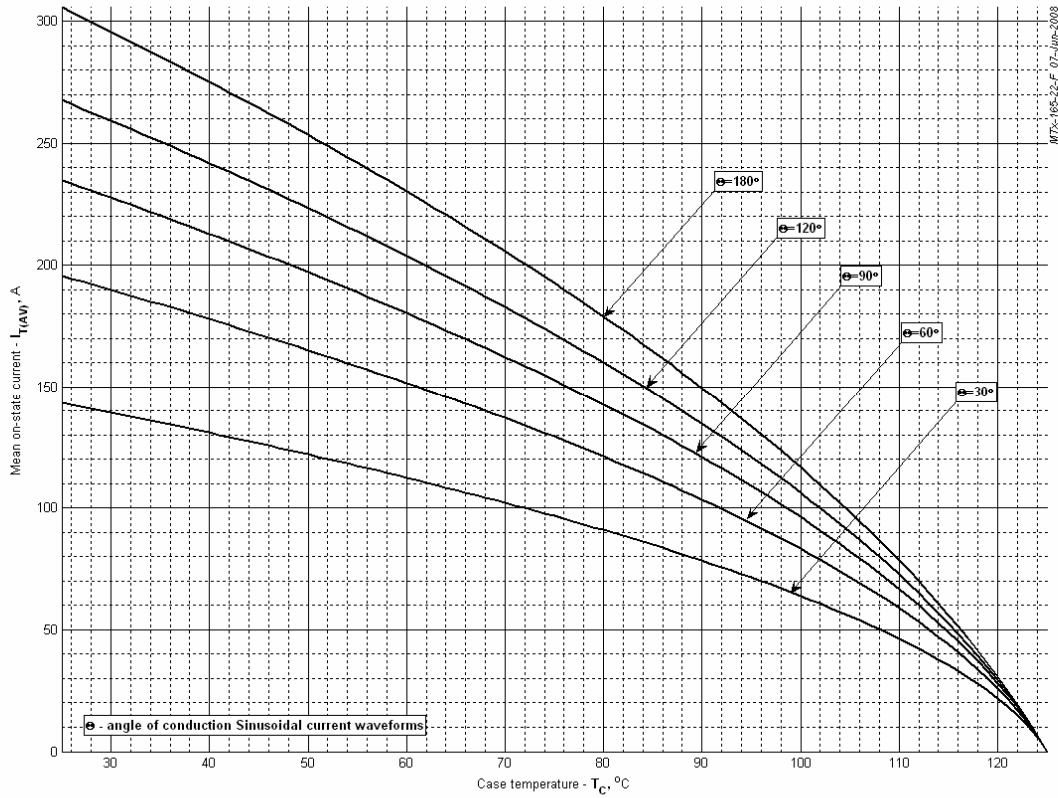
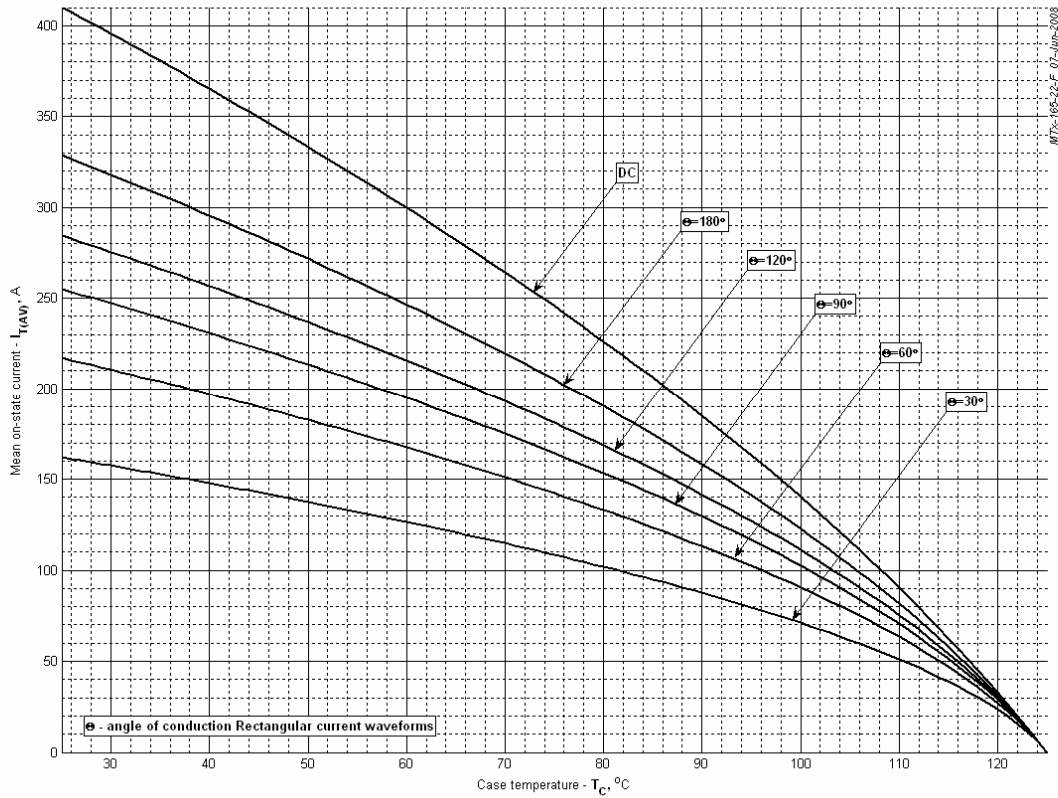

Fig 10 - On-state power loss (rectangular current waveforms)



MTX-165-22-F 07-Jun-2008

Fig 11 – Maximum case temperature (sinusoidal current waveforms)



MTX-165-22-F 07-Jun-2008

Fig 12 - Maximum case temperature (rectangular current waveforms)

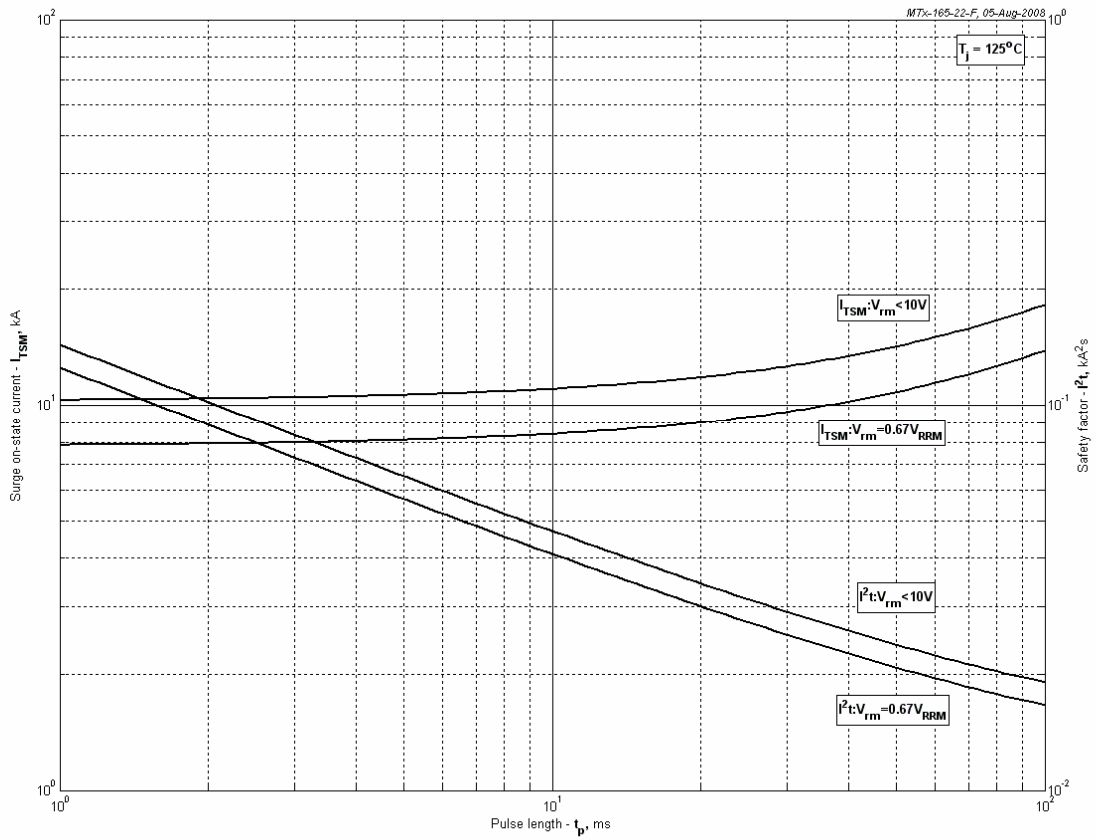

Fig 13 – Maximum surge and I^2t ratings

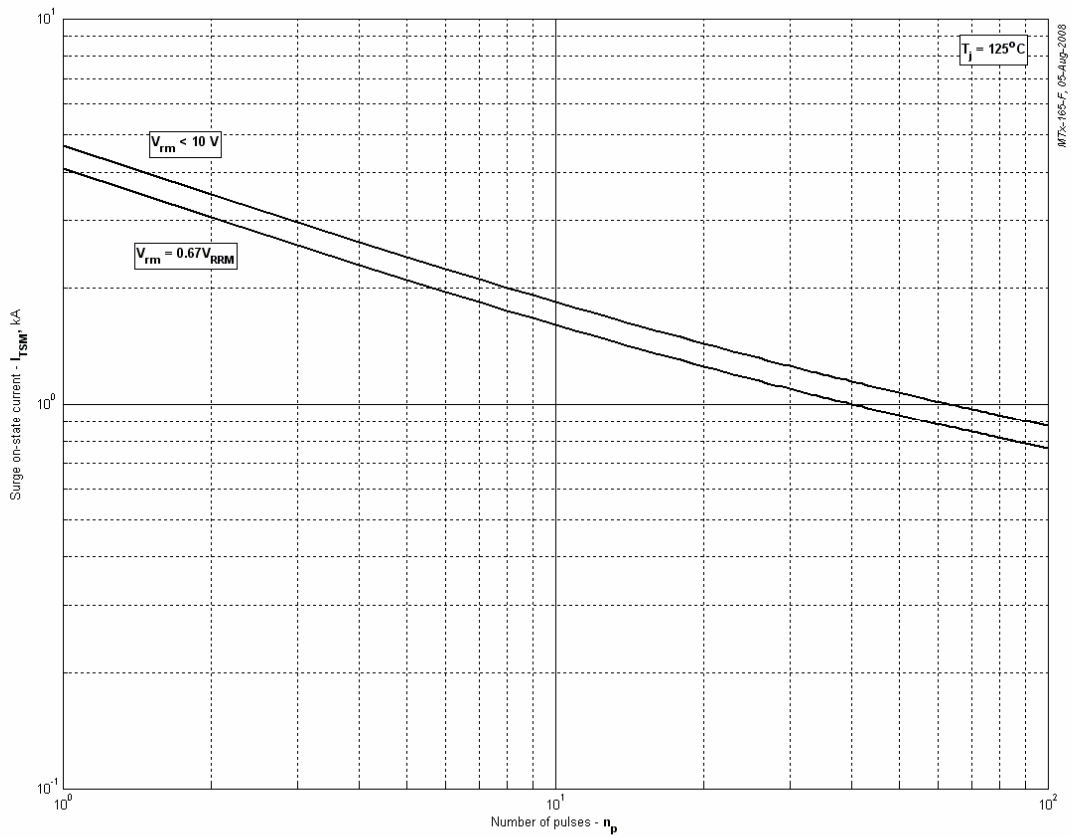

Fig 14 - Maximum surge ratings