

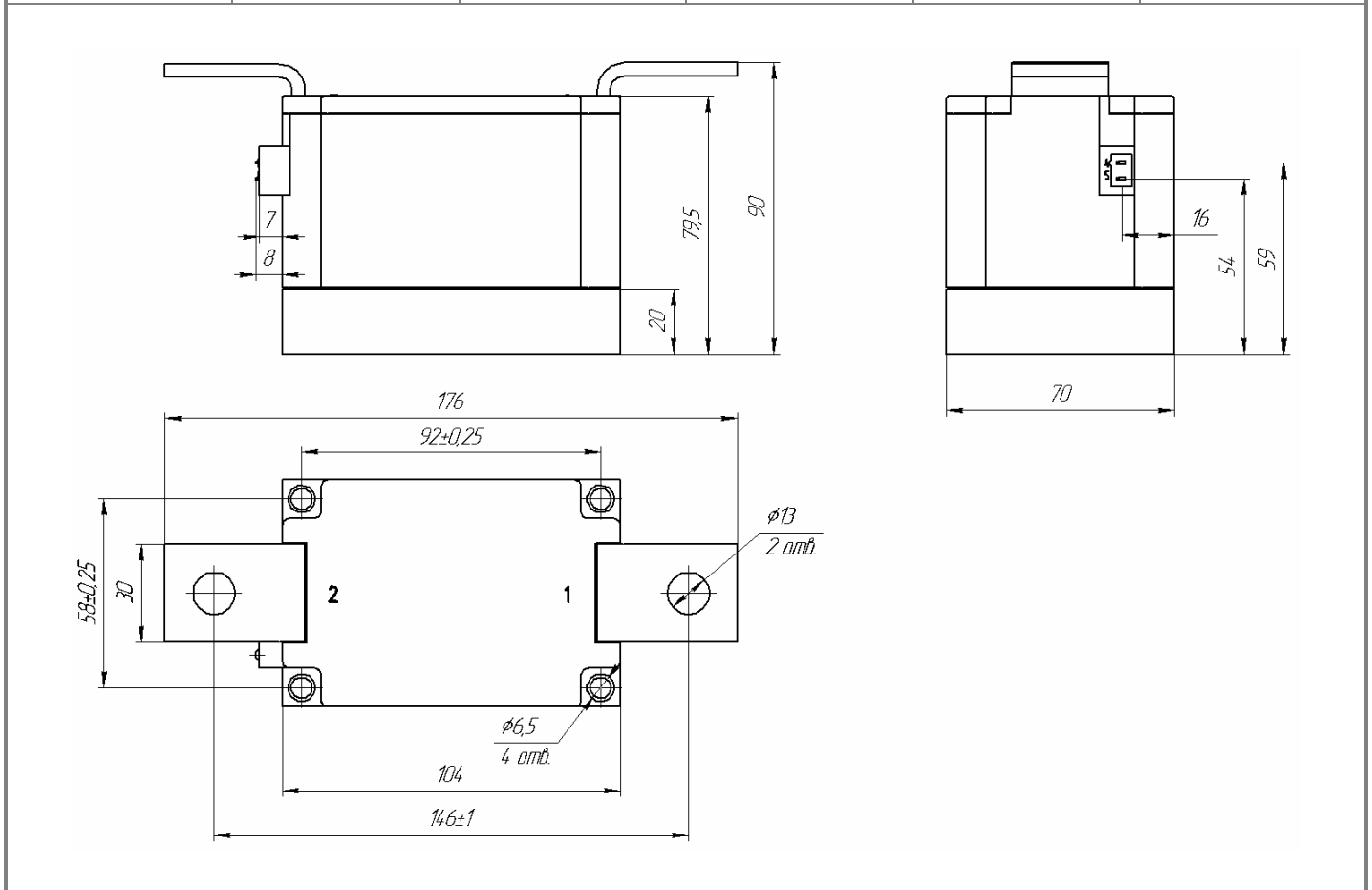

Electrically isolated base plate
Industrial standard package
Simplified mechanical design, rapid assembly
Pressure contact

Single Thyristor Module
For Phase Control
MT1-635-28-E

Mean on-state current			I_{TAV}	635 A	
Repetitive peak off-state voltage			V_{DRM}	2000 ÷ 2800 V	
Repetitive peak reverse voltage			V_{RRM}		
Turn-off time			t_q	320 μ s	
V_{DRM}, V_{RRM}, V	2000	2200	2400	2600	2800
Voltage code	20	22	24	26	28
$T_{jv}, ^\circ C$	-40 ÷ 125				

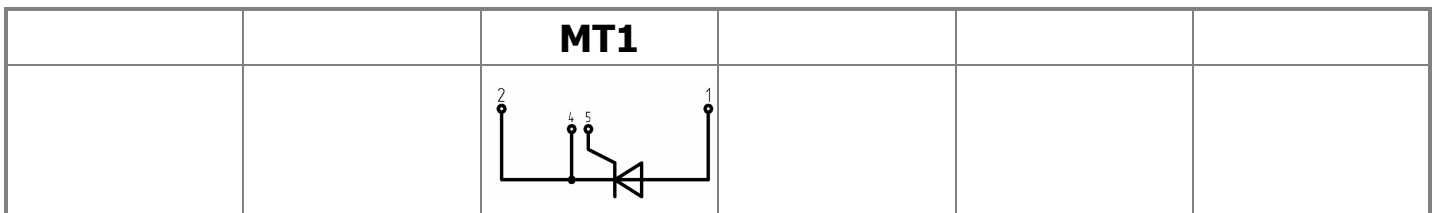

All dimensions in millimeters (inches)

MAXIMUM ALLOWABLE RATINGS

Symbols and parameters		Units	Values	Test conditions
ON-STATE				
I_{TAV}	Mean on-state current	A	635	$T_c=85\text{ }^\circ\text{C}$; 180° half-sine wave; 50 Hz
I_{TRMS}	RMS on-state current	A	997	
I_{TSM}	Surge on-state current	kA	23.0 26.0	$T_j=T_{j\text{ max}}$ $T_j=25\text{ }^\circ\text{C}$ 180° half-sine wave; 50 Hz ($t_p=10\text{ ms}$); single pulse; $V_D=V_R=0\text{ V}$; Gate pulse: $I_G=2\text{ A}$; $t_{GP}=50\text{ }\mu\text{s}$; $di_G/dt\geq 1\text{ A}/\mu\text{s}$
			25.0 29.0	$T_j=T_{j\text{ max}}$ $T_j=25\text{ }^\circ\text{C}$ 180° half-sine wave; 60 Hz ($t_p=8.3\text{ ms}$); single pulse; $V_D=V_R=0\text{ V}$; Gate pulse: $I_G=2\text{ A}$; $t_{GP}=50\text{ }\mu\text{s}$; $di_G/dt\geq 1\text{ A}/\mu\text{s}$
I^2t	Safety factor	$A^2s\cdot 10^3$	2645 3380	$T_j=T_{j\text{ max}}$ $T_j=25\text{ }^\circ\text{C}$ 180° half-sine wave; 50 Hz ($t_p=10\text{ ms}$); single pulse; $V_D=V_R=0\text{ V}$; Gate pulse: $I_G=2\text{ A}$; $t_{GP}=50\text{ }\mu\text{s}$; $di_G/dt\geq 1\text{ A}/\mu\text{s}$
			2590 3490	$T_j=T_{j\text{ max}}$ $T_j=25\text{ }^\circ\text{C}$ 180° half-sine wave; 60 Hz ($t_p=8.3\text{ ms}$); single pulse; $V_D=V_R=0\text{ V}$; Gate pulse: $I_G=2\text{ A}$; $t_{GP}=50\text{ }\mu\text{s}$; $di_G/dt\geq 1\text{ A}/\mu\text{s}$
BLOCKING				
V_{DRM}, V_{RRM}	Repetitive peak off-state and Repetitive peak reverse voltages	V	2000÷2800	$T_{j\text{ min}} < T_j < T_{j\text{ max}}$; 180° half-sine wave; 50 Hz; Gate open
V_{DSM}, V_{RSM}	Non-repetitive peak off-state and Non-repetitive peak reverse voltages	V	2100÷2900	$T_{j\text{ min}} < T_j < T_{j\text{ max}}$; 180° half-sine wave; 50 Hz; single pulse; Gate open
V_D, V_R	Direct off-state and Direct reverse voltages	V	$0.75\cdot V_{DRM}$ $0.75\cdot V_{RRM}$	$T_j=T_{j\text{ max}}$; Gate open
TRIGGERING				
I_{FGM}	Peak forward gate current	A	8	$T_j=T_{j\text{ max}}$
V_{RGM}	Peak reverse gate voltage	V	5	
P_G	Gate power dissipation	W	4	$T_j=T_{j\text{ max}}$ for DC gate current
SWITCHING				
$(di_T/dt)_{crit}$	Critical rate of rise of on-state current non-repetitive (f=1 Hz)	A/ μs	400	$T_j=T_{j\text{ max}}$; $V_D=0.67\cdot V_{DRM}$; $I_{TM}=2\text{ }I_{TAV}$; Gate pulse: $I_G=2\text{ A}$; $t_{GP}=50\text{ }\mu\text{s}$; $di_G/dt\geq 1\text{ A}/\mu\text{s}$
THERMAL				
T_{stg}	Storage temperature	$^\circ\text{C}$	-40 ÷ 125	
T_j	Operating junction temperature	$^\circ\text{C}$	-40 ÷ 125	
MECHANICAL				
a	Acceleration under vibration	m/s ²	50	

CHARACTERISTICS

Symbols and parameters		Units	Values	Conditions	
ON-STATE					
V_{TM}	Peak on-state voltage, max	V	1.40	$T_j=25\text{ }^\circ\text{C}; I_{TM}=2512\text{ A}$	
$V_{T(TO)}$	On-state threshold voltage, max	V	0.95	$T_j=T_{j\text{ max}}$	
r_T	On-state slope resistance, max	m Ω	0.350	$0.5\pi I_{TAV} < I_T < 1.5\pi I_{TAV}$	
I_L	Latching current, max	mA	1500	$T_j=25\text{ }^\circ\text{C}; V_D=12\text{ V};$ Gate pulse: $I_G=2\text{ A};$ $t_{GP}=50\text{ }\mu\text{s}; di_G/dt \geq 1\text{ A}/\mu\text{s}$	
I_H	Holding current, max	mA	300	$T_j=25\text{ }^\circ\text{C};$ $V_D=12\text{ V};$ Gate open	
BLOCKING					
I_{DRM}, I_{RRM}	Repetitive peak off-state and Repetitive peak reverse currents, max	mA	200	$T_j=T_{j\text{ max}};$ $V_D=V_{DRM}; V_R=V_{RRM}$	
$(dv_D/dt)_{crit}$	Critical rate of rise of off-state voltage, min	V/ μs	1000	$T_j=T_{j\text{ max}};$ $V_D=0.67\cdot V_{DRM};$ Gate open	
TRIGGERING					
V_{GT}	Gate trigger direct voltage, max	V	4.00 2.50 2.00	$T_j=T_{j\text{ min}}$ $T_j=25\text{ }^\circ\text{C}$ $T_j=T_{j\text{ max}}$	$V_D=12\text{ V}; I_D=3\text{ A};$ Direct gate current
I_{GT}	Gate trigger direct current, max	mA	400 250 200	$T_j=T_{j\text{ min}}$ $T_j=25\text{ }^\circ\text{C}$ $T_j=T_{j\text{ max}}$	
V_{GD}	Gate non-trigger direct voltage, min	V	0.25	$T_j=T_{j\text{ max}};$ $V_D=0.67\cdot V_{DRM};$	
I_{GD}	Gate non-trigger direct current, min	mA	10.00	Direct gate current	
SWITCHING					
t_{gd}	Delay time	μs	2.50	$T_j=25\text{ }^\circ\text{C}; V_D=0.4\cdot V_{DRM}; I_{TM}=I_{TAV};$ Gate pulse: $I_G=2\text{ A};$ $t_{GP}=50\text{ }\mu\text{s}; di_G/dt \geq 1\text{ A}/\mu\text{s}$	
t_q	Turn-off time, max	μs	320	$dv_D/dt=50\text{ V}/\mu\text{s}; T_j=T_{j\text{ max}}; I_{TM}=I_{TAV};$ $di_R/dt=-10\text{ A}/\mu\text{s}; V_R=100\text{ V};$ $V_D=0.67\cdot V_{DRM}$	
THERMAL					
R_{thjc}	Thermal resistance, junction to case			180° half-sine wave, 50 Hz	
	per module	$^\circ\text{C}/\text{W}$	0.0420		
R_{thch}	Thermal resistance, case to heatsink				
	per module	$^\circ\text{C}/\text{W}$	0.0100		
INSULATION					
V_{ISOL}	Insulation test voltage	kV	3.00	Sine wave, 50 Hz;	t=1 min
			3.60	RMS	t=1 sec
MECHANICAL					
M_1	Mounting torque (M6) ¹⁾	Nm	6.00	Tolerance $\pm 15\%$	
M_2	Terminal connection torque (M12) ¹⁾	Nm	18.00	Tolerance $\pm 10\%$	
w	Weight	g	2800		

PART NUMBERING GUIDE										NOTES	
MT	1	-	635	-	28	-	E	-	N		1) The screws must be lubricated
1	2		3		4		5		6		
1. Single Thyristor module (MT) Single Diode module (MD) 2. Circuit Schematic 3. Average On-state Current, A 4. Voltage Code 5. Package Type (M.E) 6. Ambient Conditions: N – Normal											