

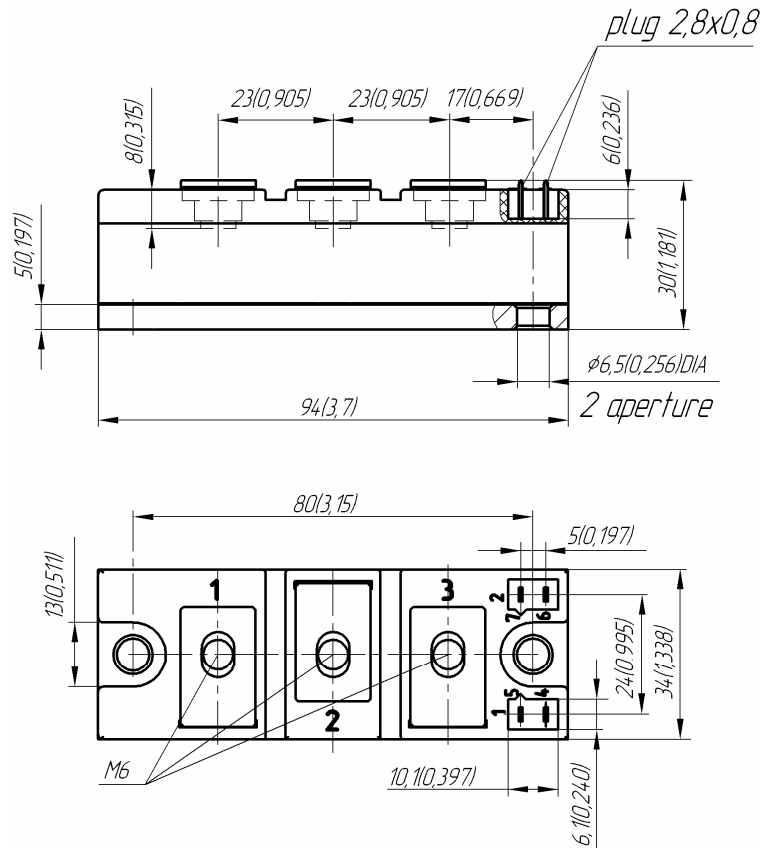

Electrically isolated base plate
Industrial standard package
Simplified mechanical design, rapid assembly
Pressure contact

**Double Diode Module
For Phase Control
MDx-155-36-F**

Average forward current		I_{FAV}	155 A	
Repetitive peak reverse voltage		V_{RRM}	3000 ÷ 3600 V	
V_{RRM}, V	3000	3200	3400	3600
Voltage code	30	32	34	36
$T_j, ^\circ C$	- 40 ÷ 150			

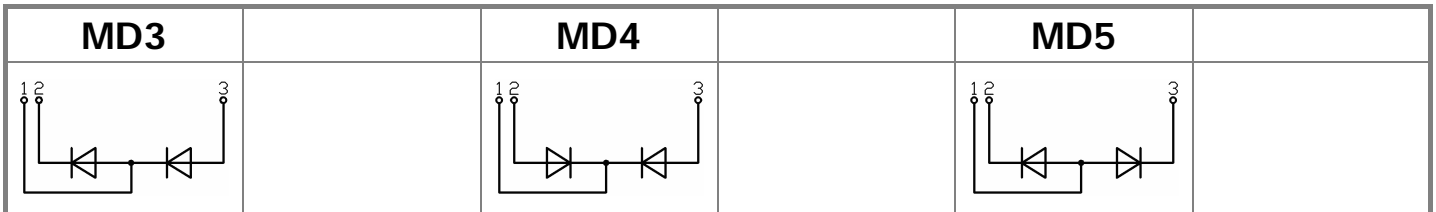

All dimensions in millimeters (inches)

JSC "PROTON-ELECTROTEX"

19 Leskova, 302027, Orel, RUSSIA, Fax : +7 (4862) 41-00-56 Phones : +7 (4862) 43-41-39 / 43-41-40

E-mail: eletex@eletex.ru / eltex@orel.ru; I-net: www.eletex.ru

MAXIMUM ALLOWABLE RATINGS

Symbols and parameters		Units	Values	Test conditions	
ON-STATE					
I_{FAV}	Average forward current	A	155	$T_c = 100\text{ }^\circ\text{C}$; 180° half-sine wave; 50 Hz	
I_{FRMS}	RMS forward current	A	243		
I_{FSM}	Surge forward current	kA	4.5 5.2	$T_j = T_{j\max}$ $T_j = 25\text{ }^\circ\text{C}$	180° half-sine wave; 50 Hz ($t_p = 10\text{ ms}$); single pulse; $V_R = 0\text{ V}$;
			4.7 5.4	$T_j = T_{j\max}$ $T_j = 25\text{ }^\circ\text{C}$	180° half-sine wave; 60 Hz ($t_p = 8.3\text{ ms}$); single pulse; $V_R = 0\text{ V}$;
I^2t	Safety factor	$A^2s \cdot 10^3$	101 134	$T_j = T_{j\max}$ $T_j = 25\text{ }^\circ\text{C}$	180° half-sine wave; 50 Hz ($t_p = 10\text{ ms}$); single pulse; $V_R = 0\text{ V}$;
			93 123	$T_j = T_{j\max}$ $T_j = 25\text{ }^\circ\text{C}$	180° half-sine wave; 60 Hz ($t_p = 8.3\text{ ms}$); single pulse; $V_R = 0\text{ V}$;
BLOCKING					
V_{RRM}	Repetitive peak reverse voltages	V	3000÷3600	$T_{j\min} < T_j < T_{j\max}$; 180° half-sine wave; 50 Hz;	
V_{RSM}	Non-repetitive peak reverse voltages	V	3100÷3700	$T_{j\min} < T_j < T_{j\max}$; 180° half-sine wave; 50 Hz; single pulse;	
V_R	Reverse continuous voltages	V	$0.75 \cdot V_{RRM}$	$T_j = T_{j\max}$;	
THERMAL					
T_{stg}	Storage temperature	$^\circ\text{C}$	- 40 ÷ 125		
T_j	Operating junction temperature	$^\circ\text{C}$	- 40 ÷ 150		
MECHANICAL					
a	Acceleration under vibration	m/s^2	50		

CHARACTERISTICS

Symbols and parameters		Units	Values	Conditions	
ON-STATE					
V_{FM}	Peak forward voltage, max	V	2.00	$T_j = 25\text{ }^\circ\text{C}$; $I_{FM} = 500\text{ A}$	
$V_{F(TO)}$	Forward threshold voltage, max	V	0.93	$T_j = T_{j\max}$; $0.5 \pi I_{FAV} < I_T < 1.5 \pi I_{FAV}$	
r_T	Forward slope resistance, max	$\text{m}\Omega$	2.000		
BLOCKING					
I_{RRM}	Repetitive peak reverse current, max	mA	50	$T_j = T_{j\max}$; $V_R = V_{RRM}$	
THERMAL					
R_{thjc}	Thermal resistance, junction to case			180° half-sine wave, 50 Hz	
	per module	$^\circ\text{C/W}$	0.0950		
	per arm	$^\circ\text{C/W}$	0.1900		
	per module	$^\circ\text{C/W}$	0.0900	DC	
per arm	$^\circ\text{C/W}$	0.1800			
R_{thch}	Thermal resistance, case to heatsink				
	per module	$^\circ\text{C/W}$	0.0300		
	per arm	$^\circ\text{C/W}$	0.0600		

JSC "PROTON-ELECTROTEX"

19 Leskova, 302027, Orel, RUSSIA, Fax : +7 (4862) 41-00-56 Phones : +7 (4862) 43-41-39 / 43-41-40

E-mail: eletex@eletex.ru / eltex@orel.ru; I-net: www.eletex.ru

INSULATION					
V _{ISOL}	Insulation test voltage	kV	3.00	Sine wave, 50 Hz; RMS	t=1 min
			3.60		t=1 sec
MECHANICAL					
M ₁	Mounting torque (M6) ¹⁾	Nm	6.00	Tolerance ± 15%	
M ₂	Terminal connection torque (M6) ¹⁾	Nm	6.00	Tolerance ± 10%	
w	Weight	g	320		

PART NUMBERING GUIDE						NOTES					
MD	3	-	155	-	36	-	F	-	N		
1	2		3		4		5		6		
1. MD - Rectifier Diode 2. Circuit Schematic 3. Average Forward Current, A 4. Voltage Code 5. Package Type (M.F) 6. Ambient Conditions: N – Normal											¹⁾ The screws must be lubricated

The information contained herein is confidential and protected by Copyright.
 In the interest of product improvement, Proton-Electrotex reserves the right to change data sheet without notice.