

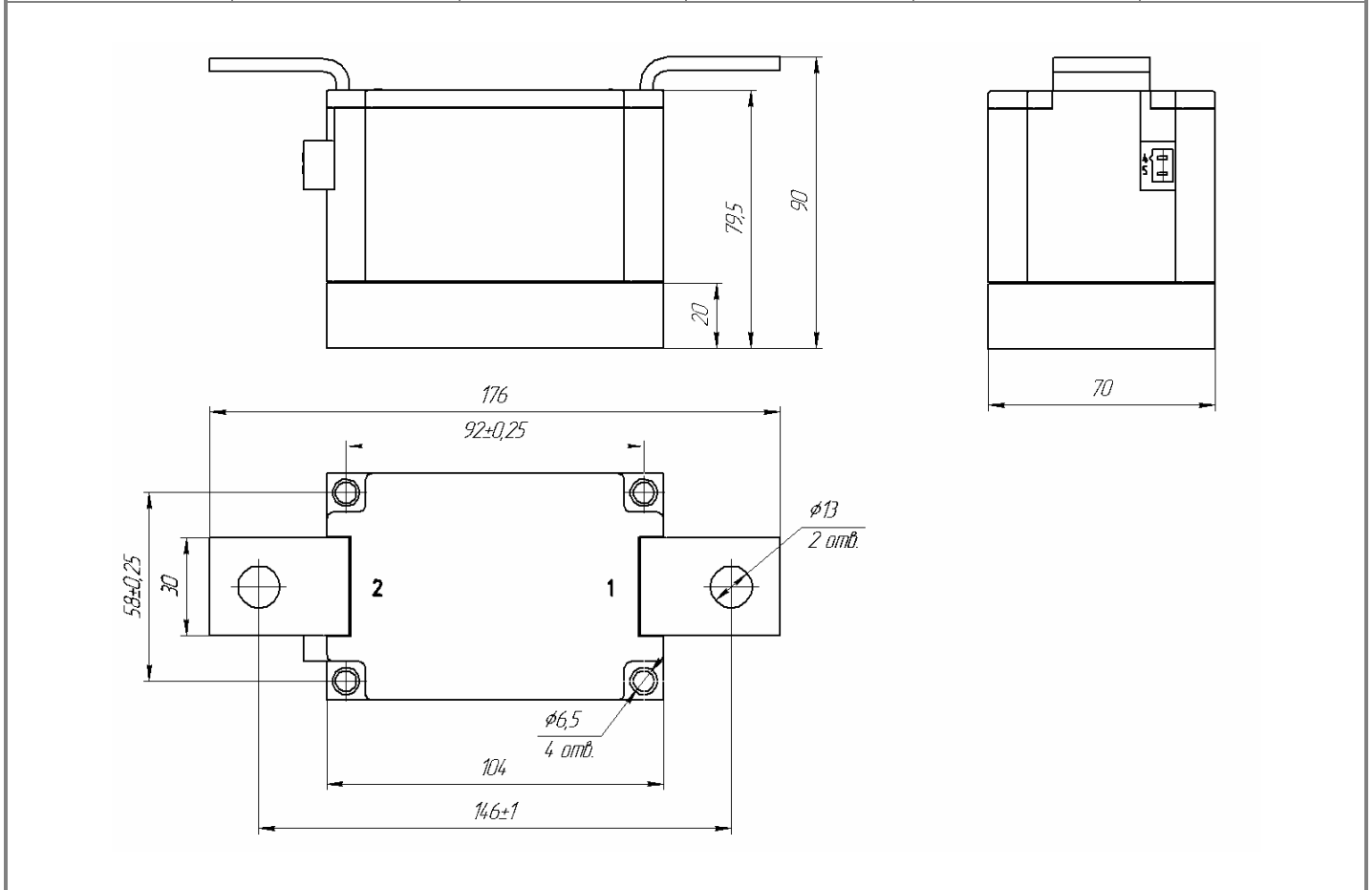

**Double Diode Module**  
**For Phase Control**  
**MD1-1125-28-E**

Electrically isolated base plate  
Industrial standard package  
Simplified mechanical design, rapid assembly  
Pressure contact

Average forward current		I <sub>FAV</sub>		1125 A	
Repetitive peak reverse voltage		V <sub>RRM</sub>		2000 ÷ 2800 V	
V <sub>RRM</sub> , V	2000	2200	2400	2600	2800
Voltage code	20	22	24	26	28
T <sub>j</sub> , °C	- 40 ÷ 160				

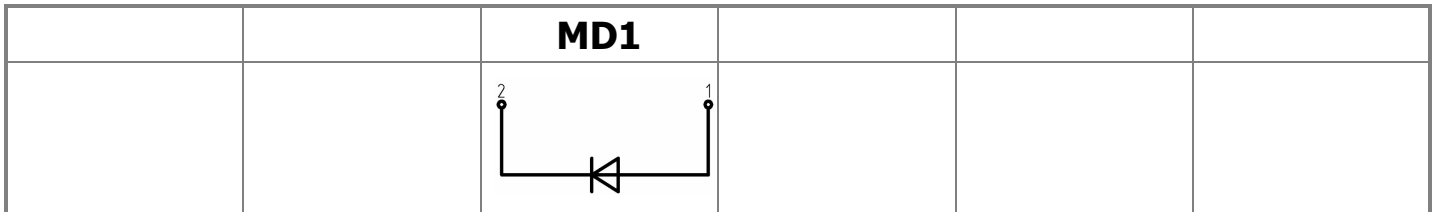

All dimensions in millimeters (inches)

## MAXIMUM ALLOWABLE RATINGS

Symbols and parameters		Units	Values	Test conditions
<b>ON-STATE</b>				
$I_{FAV}$	Average forward current	A	1125	$T_c = 100\text{ }^\circ\text{C}$ ; 180° half-sine wave; 50 Hz
$I_{FRMS}$	RMS forward current	A	1766	
$I_{FSM}$	Surge forward current	kA	36.0 41.0	$T_j = T_{j\text{ max}}$ $T_j = 25\text{ }^\circ\text{C}$ 180° half-sine wave; 50 Hz ( $t_p = 10\text{ ms}$ ); single pulse; $V_R = 0\text{ V}$ ;
			38.0 44.0	$T_j = T_{j\text{ max}}$ $T_j = 25\text{ }^\circ\text{C}$ 180° half-sine wave; 60 Hz ( $t_p = 8.3\text{ ms}$ ); single pulse; $V_R = 0\text{ V}$ ;
$I^2t$	Safety factor	$A^2s \cdot 10^3$	6480 8405	$T_j = T_{j\text{ max}}$ $T_j = 25\text{ }^\circ\text{C}$ 180° half-sine wave; 50 Hz ( $t_p = 10\text{ ms}$ ); single pulse; $V_R = 0\text{ V}$ ;
			5990 8030	$T_j = T_{j\text{ max}}$ $T_j = 25\text{ }^\circ\text{C}$ 180° half-sine wave; 60 Hz ( $t_p = 8.3\text{ ms}$ ); single pulse; $V_R = 0\text{ V}$ ;
<b>BLOCKING</b>				
$V_{RRM}$	Repetitive peak reverse voltages	V	2000÷2800	$T_{j\text{ min}} < T_j < T_{j\text{ max}}$ ; 180° half-sine wave; 50 Hz;
$V_{RSM}$	Non-repetitive peak reverse voltages	V	2100÷2900	$T_{j\text{ min}} < T_j < T_{j\text{ max}}$ ; 180° half-sine wave; 50 Hz; single pulse;
$V_R$	Reverse continuous voltages	V	$0.75 \cdot V_{RRM}$	$T_j = T_{j\text{ max}}$ ;
<b>THERMAL</b>				
$T_{stg}$	Storage temperature	$^\circ\text{C}$	- 40 ÷ 125	
$T_j$	Operating junction temperature	$^\circ\text{C}$	- 40 ÷ 160	
<b>MECHANICAL</b>				
a	Acceleration under vibration	$\text{m/s}^2$	50	

## CHARACTERISTICS

Symbols and parameters		Units	Values	Conditions
<b>ON-STATE</b>				
$V_{FM}$	Peak forward voltage, max	V	1.38	$T_j = 25\text{ }^\circ\text{C}$ ; $I_{FM} = 3140\text{ A}$
$V_{F(TO)}$	Forward threshold voltage, max	V	0.80	$T_j = T_{j\text{ max}}$ ; $0.5 \pi I_{FAV} < I_T < 1.5 \pi I_{FAV}$
$r_T$	Forward slope resistance, max	$\text{m}\Omega$	0.170	
<b>BLOCKING</b>				
$I_{RRM}$	Repetitive peak reverse current, max	mA	70	$T_j = T_{j\text{ max}}$ ; $V_R = V_{RRM}$
<b>THERMAL</b>				
$R_{thjc}$	Thermal resistance, junction to case			180° half-sine wave, 50 Hz
	per module	$^\circ\text{C/W}$	0.0420	
$R_{thch}$	Thermal resistance, case to heatsink			
	per module	$^\circ\text{C/W}$	0.0100	
<b>INSULATION</b>				
$V_{ISOL}$	Insulation test voltage	kV	3.00	Sine wave, 50 Hz; RMS
			3.60	
<b>MECHANICAL</b>				
$M_1$	Mounting torque (M6) <sup>1)</sup>	Nm	6.00	Tolerance $\pm 15\%$
$M_2$	Terminal connection torque (M12) <sup>1)</sup>	Nm	18.00	Tolerance $\pm 10\%$
w	Weight	g	2800	

PART NUMBERING GUIDE										NOTES	
MD	1	-	1125	-	28	-	E	-	N		1) The screws must be lubricated
1	2		3		4		5		6		
1. MD - Rectifier Diode 2. Circuit Schematic 3. Average Forward Current, A 4. Voltage Code 5. Package Type (M.E) 6. Ambient Conditions: N – Normal											