



High power cycling capability
Low on-state and switching losses
Designed for traction and industrial applications

Phase Control Thyristor Type T123-500-8

Mean on-state current	I_{TAV}		500 A					
Repetitive peak off-state voltage	V_{DRM}		100 ÷ 800 V					
Repetitive peak reverse voltage	V_{RRM}							
Turn-off time	t_q		80 μ s					
V_{DRM}, V_{RRM}, V	100	200	300	400	500	600	700	800
Voltage code	1	2	3	4	5	6	7	8
$T_j, ^\circ C$	-60 ÷ 150							

MAXIMUM ALLOWABLE RATINGS

Symbols and parameters		Units	Values	Test conditions	
ON-STATE					
I_{TAV}	Mean on-state current	A	500 605	$T_c=100^\circ C$, Double side cooled $T_c=85^\circ C$, Double side cooled 180° half-sine wave; 50 Hz	
I_{TRMS}	RMS on-state current	A	785	$T_c=100^\circ C$, Double side cooled 180° half-sine wave; 50 Hz	
I_{TSM}	Surge on-state current	kA	6.0 6.9	$T_j=T_{jmax}$ $T_j=25^\circ C$	180° half-sine wave; 50 Hz ($t_p=10$ ms); single pulse; $V_D=V_R=0$ V; Gate pulse: $I_G=2$ A; $t_{GP}=50 \mu s$; $di_G/dt \geq 1$ A/ μs
			7.0 8.1		180° half-sine wave; 60 Hz ($t_p=8.3$ ms); single pulse; $V_D=V_R=0$ V; Gate pulse: $I_G=2$ A; $t_{GP}=50 \mu s$; $di_G/dt \geq 1$ A/ μs
I^2t	Safety factor	$A^2s \cdot 10^3$	180 235	$T_j=T_{jmax}$ $T_j=25^\circ C$	180° half-sine wave; 50 Hz ($t_p=10$ ms); single pulse; $V_D=V_R=0$ V; Gate pulse: $I_G=2$ A; $t_{GP}=50 \mu s$; $di_G/dt \geq 1$ A/ μs
			200 270		180° half-sine wave; 60 Hz ($t_p=8.3$ ms); single pulse; $V_D=V_R=0$ V; Gate pulse: $I_G=2$ A; $t_{GP}=50 \mu s$; $di_G/dt \geq 1$ A/ μs
BLOCKING					
V_{DRM}, V_{RRM}	Repetitive peak off-state and Repetitive peak reverse voltages	V	100 ÷ 800	$T_{jmin} < T_j < T_{jmax}$; 180° half-sine wave; 50 Hz; Gate open	
V_{DSM}, V_{RSM}	Non-repetitive peak off-state and Non-repetitive peak reverse voltages	V	200 ÷ 900	$T_{jmin} < T_j < T_{jmax}$; 180° half-sine wave; 50 Hz; single pulse; Gate open	
V_D, V_R	Direct off-state and Direct reverse voltages	V	$0.75 \cdot V_{DRM}$ $0.75 \cdot V_{RRM}$	$T_j=T_{jmax}$; Gate open	

TRIGGERING				
I_{FGM}	Peak forward gate current	A	5	$T_j = T_{j\ max}$
V_{RGM}	Peak reverse gate voltage	V	5	
P_G	Gate power dissipation	W	3	$T_j = T_{j\ max}$ for DC gate current
SWITCHING				
$(di_T/dt)_{crit}$	Critical rate of rise of on-state current non-repetitive (f=1 Hz)	A/ μ s	250	$T_j = T_{j\ max}; V_D = 0.67 \cdot V_{DRM}; I_{TM} = 2 I_{TAV};$ Gate pulse: $I_G = 2\ A;$ $t_{GP} = 50\ \mu s; di_G/dt \geq 1\ A/\mu s$
THERMAL				
T_{stg}	Storage temperature	$^{\circ}C$	-60÷150	
T_j	Operating junction temperature	$^{\circ}C$	-60÷150	
MECHANICAL				
F	Mounting force	kN	5.0÷7.0	
a	Acceleration	m/s^2	50 100	Device unclamped Device clamped

CHARACTERISTICS

Symbols and parameters		Units	Values	Conditions	
ON-STATE					
V_{TM}	Peak on-state voltage, max	V	1.55	$T_j = 25\ ^{\circ}C; I_{TM} = 1570\ A$	
$V_{T(TO)}$	On-state threshold voltage, max	V	0.80	$T_j = T_{j\ max};$	
r_T	On-state slope resistance, max	$m\Omega$	0.490	$0.5\ \pi\ I_{TAV} < I_T < 1.5\ \pi\ I_{TAV}$	
I_L	Latching current, max	mA	500	$T_j = 25\ ^{\circ}C; V_D = 12\ V;$ Gate pulse: $I_G = 2\ A;$ $t_{GP} = 50\ \mu s; di_G/dt \geq 1\ A/\mu s$	
I_H	Holding current, max	mA	250	$T_j = 25\ ^{\circ}C;$ $V_D = 12\ V;$ Gate open	
BLOCKING					
I_{DRM}, I_{RRM}	Repetitive peak off-state and Repetitive peak reverse currents, max	mA	50	$T_j = T_{j\ max};$ $V_D = V_{DRM}; V_R = V_{RRM}$	
$(dv_D/dt)_{crit}$	Critical rate of rise of off-state voltage ¹⁾ , min	V/ μ s	1000	$T_j = T_{j\ max};$ $V_D = 0.67 \cdot V_{DRM};$ Gate open	
TRIGGERING					
V_{GT}	Gate trigger direct voltage, max	V	4.00	$T_j = T_{j\ min}$ $T_j = 25\ ^{\circ}C$ $T_j = T_{j\ max}$	$V_D = 12\ V; I_D = 3\ A;$ Direct gate current
			2.50		
			2.00		
I_{GT}	Gate trigger direct current, max	mA	400	$T_j = T_{j\ min}$ $T_j = 25\ ^{\circ}C$ $T_j = T_{j\ max}$	
			250		
			200		
V_{GD}	Gate non-trigger direct voltage, min	V	0.25	$T_j = T_{j\ max};$ $V_D = 0.67 \cdot V_{DRM};$	
I_{GD}	Gate non-trigger direct current, min	mA	10.00	Direct gate current	
SWITCHING					
t_{gd}	Delay time	μ s	1.60	$T_j = 25\ ^{\circ}C; V_D = 0.4 \cdot V_{DRM}; I_{TM} = I_{TAV};$ Gate pulse: $I_G = 2\ A;$ $t_{GP} = 50\ \mu s; di_G/dt \geq 1\ A/\mu s$	
t_q	Turn-off time ²⁾ , max	μ s	80	$dv_D/dt = 50\ V/\mu s; T_j = T_{j\ max}; I_{TM} = I_{TAV};$ $di_R/dt = -10\ A/\mu s; V_R = 100V;$ $V_D = 0.67 \cdot V_{DRM}$	

THERMAL					
R_{thjc}	Thermal resistance, junction to case, max	°C/W	0.070	Direct current	Double side cooled
R_{thjc-A}			0.154		Anode side cooled
R_{thjc-K}			0.126		Cathode side cooled
R_{thck}	Thermal resistance, case to heatsink, max	°C/W	0.010	Direct current	
MECHANICAL					
w	Weight, typ	g	70		
D_s	Surface creepage distance	mm (inch)	7.94 (0.313)		
D_a	Air strike distance	mm (inch)	5.00 (0.197)		

PART NUMBERING GUIDE

T	123	500	8	N
1	2	3	4	5

1. Phase Control Thyristor
2. Design version
3. Mean on-state current, A
4. Voltage code
5. Ambient conditions: N – normal; T – tropical

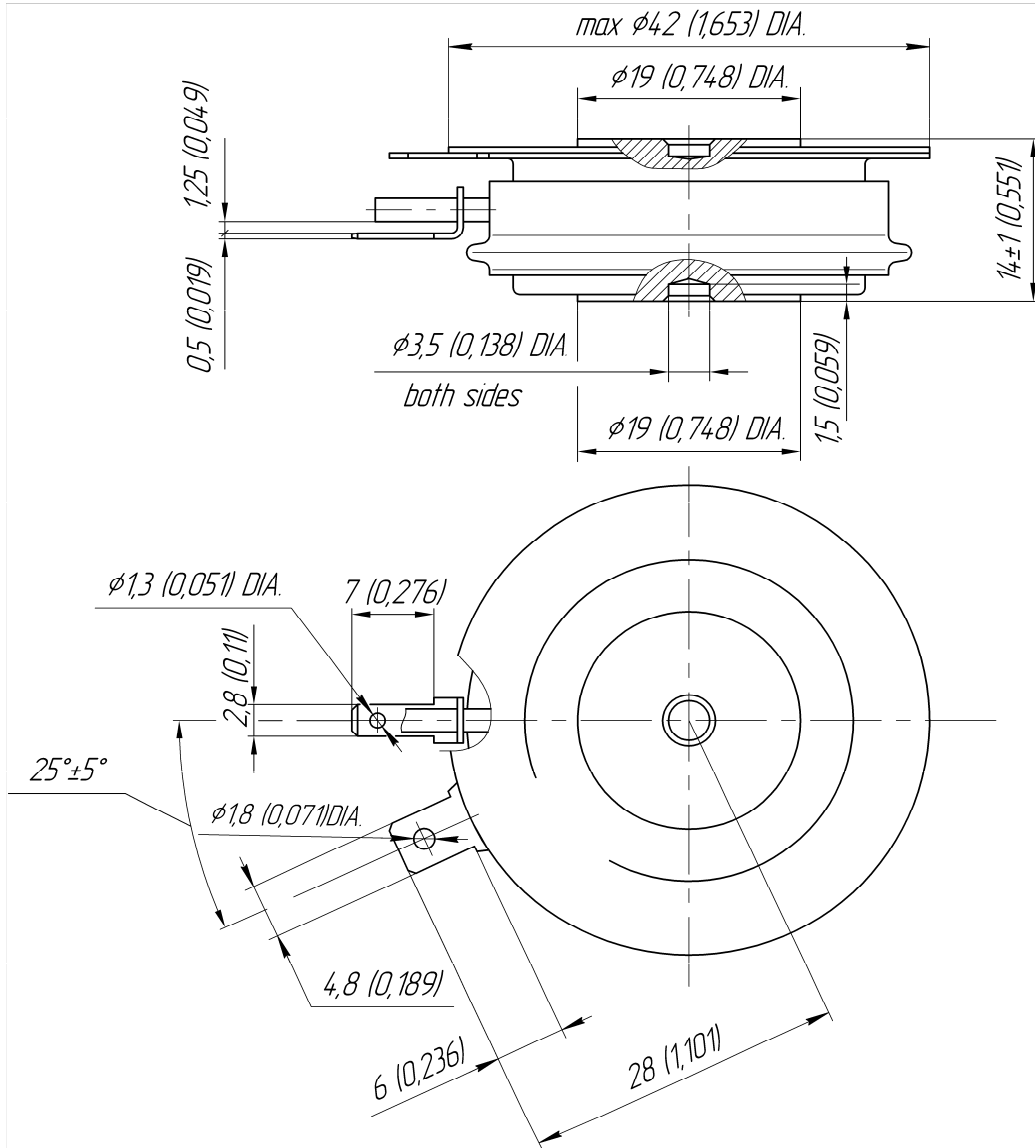

All dimensions in millimeters (inches)

The information contained herein is confidential and protected by Copyright. In the interest of product improvement, Proton-Electrotex reserves the right to change data sheet without notice.