



Low switching losses  
Low reverse recovery charge  
High power cycling capability

**Fast Recovery Diode**  
**Type DF273-2000-24**

Average forward current	$I_{FAV}$	2000 A	
Repetitive peak reverse voltage	$V_{RRM}$	2000 ÷ 2400 V	
Reverse recovery time	$t_{rr}$	8.0 $\mu$ s	
$V_{RRM}$ , V	2000	2200	2400
Voltage code	20	22	24
$T_j$ , °C	- 60 ÷ 125		

**MAXIMUM ALLOWABLE RATINGS**

Symbols and parameters		Units	Values	Test conditions
<b>ON-STATE</b>				
$I_{FAV}$	Average forward current	A	2000 3280	$T_c=90$ °C; Double side cooled; $T_c=55$ °C; Double side cooled; 180° half-sine wave; 50 Hz
$I_{FRMS}$	RMS forward current	A	3140	$T_c=90$ °C; Double side cooled; 180° half-sine wave; 50 Hz
$I_{FSM}$	Surge forward current	kA	46.0 53.0	$T_j=T_{j\ max}$ $T_j=25$ °C 180° half-sine wave; 50 Hz ( $t_p=10$ ms); single pulse; $V_R=0$ V;
			49.0 56.0	$T_j=T_{j\ max}$ $T_j=25$ °C 180° half-sine wave; 60 Hz ( $t_p=8.3$ ms); single pulse; $V_R=0$ V;
$I^2t$	Safety factor	$A^2s \cdot 10^3$	10580 14045	$T_j=T_{j\ max}$ $T_j=25$ °C 180° half-sine wave; 50 Hz ( $t_p=10$ ms); single pulse; $V_R=0$ V;
			9960 13010	$T_j=T_{j\ max}$ $T_j=25$ °C 180° half-sine wave; 60 Hz ( $t_p=8.3$ ms); single pulse; $V_R=0$ V;
<b>BLOCKING</b>				
$V_{RRM}$	Repetitive peak reverse voltages	V	2000÷2400	$T_{j\ min} < T_j < T_{j\ max}$ ; 180° half-sine wave; 50 Hz;
$V_{RSM}$	Non-repetitive peak reverse voltages	V	2100÷2500	$T_{j\ min} < T_j < T_{j\ max}$ ; 180° half-sine wave; 50 Hz; single pulse;
$V_R$	Reverse continuous voltages	V	$0.75 \cdot V_{RRM}$	$T_j = T_{j\ max}$ ;
<b>THERMAL</b>				
$T_{stg}$	Storage temperature	°C	- 60 ÷ 125	
$T_j$	Operating junction temperature	°C	- 60 ÷ 125	
<b>MECHANICAL</b>				
F	Mounting force	kN	40.0 ÷ 50.0	
a	Acceleration	$m/s^2$	50	Device unclamped
			100	Device clamped

**JSC "PROTON-ELECTROTEX"**

19 Leskova, 302027, Orel, RUSSIA, Fax : +7 (4862) 41-00-56 Phones : +7 (4862) 43-41-39 / 43-41-40

E-mail: [eletex@eletex.ru](mailto:eletex@eletex.ru) / [eltex@orel.ru](mailto:eltex@orel.ru); I-net: [www.eletex.ru](http://www.eletex.ru)

## CHARACTERISTICS

Symbols and parameters		Units	Values	Conditions	
<b>ON-STATE</b>					
$V_{FM}$	Peak forward voltage, max	V	1.85	$T_j=25\text{ }^\circ\text{C}; I_{FM}=6280\text{ A}$	
$V_{F(TO)}$	Forward threshold voltage, max	V	1.30	$T_j=T_{j\text{ max}}$	
$r_T$	Forward slope resistance, max	m $\Omega$	0.150	$0.5\pi I_{FAV} < I_T < 1.5\pi I_{FAV}$	
<b>BLOCKING</b>					
$I_{RRM}$	Repetitive peak reverse current, max	mA	200	$T_j=T_{j\text{ max}};$ $V_R=V_{RRM}$	
<b>SWITCHING</b>					
$Q_{rr}$	Total recovered charge, max	$\mu\text{C}$	1800	$T_j=T_{j\text{ max}}; I_{FM}=I_{FAV};$	
$t_{rr}$	Reverse recovery time, max	$\mu\text{s}$	8.0	$di_R/dt=-100\text{ A}/\mu\text{s};$	
$I_{rrM}$	Peak reverse recovery current, max	A	450	$V_R=100\text{ V};$	
<b>THERMAL</b>					
$R_{thjc}$	Thermal resistance, junction to case, max	$^\circ\text{C}/\text{W}$	0.0085	Direct current	Double side cooled
$R_{thjc-A}$			0.0187		Anode side cooled
$R_{thjc-K}$			0.0153		Cathode side cooled
$R_{thck}$	Thermal resistance, case to heatsink, max	$^\circ\text{C}/\text{W}$	0.0020	Direct current	
<b>MECHANICAL</b>					
w	Weight, typ	g	1500		
$D_s$	Surface creepage distance	mm (inch)	41.40 (1.630)		
$D_a$	Air strike distance	mm (inch)	23.10 (0.909)		

PART NUMBERING GUIDE						GROUP OF RECOVERY TIME	
DF	273	2000	24	B4	N	Group Symbol	
1	2	3	4	5	6	$t_{rr}, \mu\text{s}$	B4 8.0
1. Fast recovery diode 2. Design version 3. Average forward current, A 4. Voltage code 5. Group of reverse recovery time 6. Ambient conditions: N – normal; T – tropical							

### JSC "PROTON-ELECTROTEX"

19 Leskova, 302027, Orel, RUSSIA, Fax : +7 (4862) 41-00-56 Phones : +7 (4862) 43-41-39 / 43-41-40

E-mail: [eletex@eletex.ru](mailto:eletex@eletex.ru) / [eltex@orel.ru](mailto:eltex@orel.ru); I-net: [www.eletex.ru](http://www.eletex.ru)

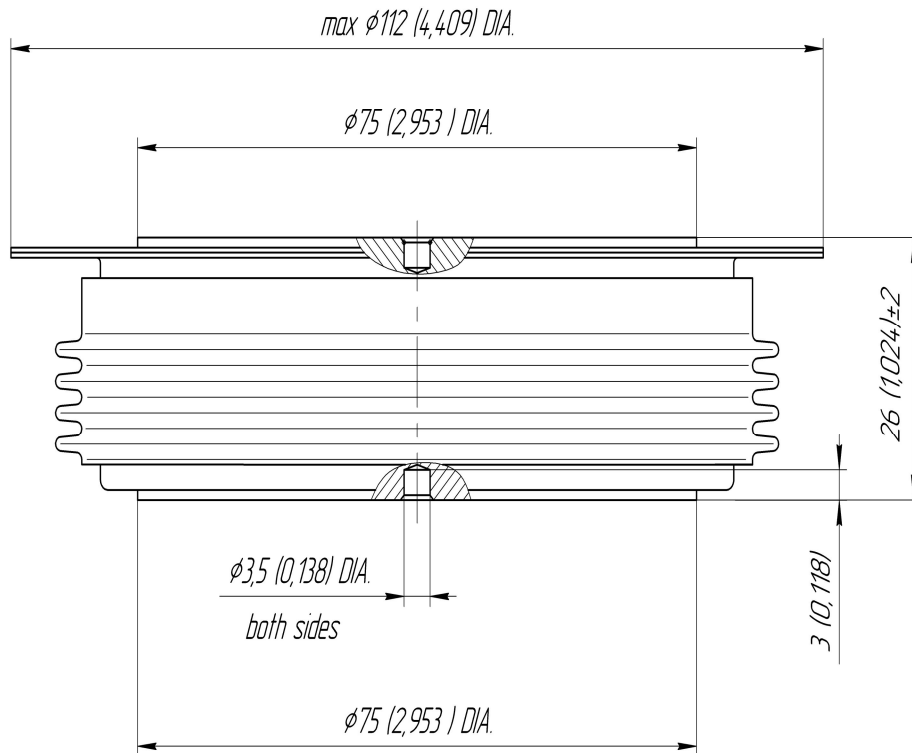

All dimensions in millimeters (inches)

The information contained herein is confidential and protected by Copyright.  
 In the interest of product improvement, Proton-Electrotex reserves the right to change data sheet without notice.

**JSC "PROTON-ELECTROTEX"**

19 Leskova, 302027, Orel, RUSSIA, Fax : +7 (4862) 41-00-56 Phones : +7 (4862) 43-41-39 / 43-41-40

E-mail: [eletex@eletex.ru](mailto:eletex@eletex.ru) / [eltex@orel.ru](mailto:eltex@orel.ru); I-net: [www.eletex.ru](http://www.eletex.ru)