



Low switching losses
Low reverse recovery charge
High power cycling capability

Fast Recovery Diode
Type DF153-630-18

Average forward current		I_{FAV}	630 A		
Repetitive peak reverse voltage		V_{RRM}	1000 ÷ 1800 V		
Reverse recovery time		t_{rr}	2.5 μ s		
V_{RRM} , V	1000	1200	1400	1600	1800
Voltage code	10	12	14	16	18
T_j , °C	- 60 ÷ 125				

MAXIMUM ALLOWABLE RATINGS

Symbols and parameters		Units	Values	Test conditions	
ON-STATE					
I_{FAV}	Average forward current	A	630 1600	$T_c=105$ °C; Double side cooled; $T_c=55$ °C; Double side cooled; 180° half-sine wave; 50 Hz	
I_{FRMS}	RMS forward current	A	989	$T_c=105$ °C; Double side cooled; 180° half-sine wave; 50 Hz	
I_{FSM}	Surge forward current	kA	25.0 29.0	$T_j=T_{j\max}$ $T_j=25$ °C	180° half-sine wave; 50 Hz ($t_p=10$ ms); single pulse; $V_R=0$ V;
			27.0 31.0	$T_j=T_{j\max}$ $T_j=25$ °C	180° half-sine wave; 60 Hz ($t_p=8.3$ ms); single pulse; $V_R=0$ V;
I^2t	Safety factor	$A^2s \cdot 10^3$	3125 4205	$T_j=T_{j\max}$ $T_j=25$ °C	180° half-sine wave; 50 Hz ($t_p=10$ ms); single pulse; $V_R=0$ V;
			3025 3985	$T_j=T_{j\max}$ $T_j=25$ °C	180° half-sine wave; 60 Hz ($t_p=8.3$ ms); single pulse; $V_R=0$ V;
BLOCKING					
V_{RRM}	Repetitive peak reverse voltages	V	1000÷1800	$T_{j\min} < T_j < T_{j\max}$; 180° half-sine wave; 50 Hz;	
V_{RSM}	Non-repetitive peak reverse voltages	V	1100÷1900	$T_{j\min} < T_j < T_{j\max}$; 180° half-sine wave; 50 Hz; single pulse;	
V_R	Reverse continuous voltages	V	$0.75 \cdot V_{RRM}$	$T_j = T_{j\max}$;	
THERMAL					
T_{stg}	Storage temperature	°C	- 60 ÷ 125		
T_j	Operating junction temperature	°C	- 60 ÷ 125		
MECHANICAL					
F	Mounting force	kN	24.0 ÷ 28.0		
a	Acceleration	m/s^2	50	Device unclamped	
			100	Device clamped	

CHARACTERISTICS

Symbols and parameters		Units	Values	Conditions	
ON-STATE					
V_{FM}	Peak forward voltage, max	V	3.00	$T_j=25\text{ }^\circ\text{C}; I_{FM}=1978\text{ A}$	
$V_{F(TO)}$	Forward threshold voltage, max	V	1.25	$T_j=T_{j\text{ max}}$	
r_T	Forward slope resistance, max	m Ω	0.300	$0.5\pi I_{FAV} < I_T < 1.5\pi I_{FAV}$	
BLOCKING					
I_{RRM}	Repetitive peak reverse current, max	mA	150	$T_j=T_{j\text{ max}}$ $V_R=V_{RRM}$	
SWITCHING					
Q_{rr}	Total recovered charge, max	μC	120	$T_j=T_{j\text{ max}}; I_{FM}=I_{FAV};$	
t_{rr}	Reverse recovery time, max	μs	2.5	$di_R/dt=-100\text{ A}/\mu\text{s};$	
I_{rrM}	Peak reverse recovery current, max	A	96	$V_R=100\text{ V};$	
THERMAL					
R_{thjc}	Thermal resistance, junction to case, max	$^\circ\text{C}/\text{W}$	0.0180	Direct current	Double side cooled
R_{thjc-A}			0.0396		Anode side cooled
R_{thjc-K}			0.0324		Cathode side cooled
R_{thck}	Thermal resistance, case to heatsink, max	$^\circ\text{C}/\text{W}$	0.0040	Direct current	
MECHANICAL					
w	Weight, typ	g	510		
D_s	Surface creepage distance	mm (inch)	38.84 (1.529)		
D_a	Air strike distance	mm (inch)	22.50 (0.886)		

PART NUMBERING GUIDE						GROUP OF RECOVERY TIME	
DF	153	630	18	M4	N	Group Symbol	
1	2	3	4	5	6	$t_{rr}, \mu\text{s}$	
1. Fast recovery diode 2. Design version 3. Average forward current, A 4. Voltage code 5. Group of reverse recovery time 6. Ambient conditions: N – normal; T – tropical						M4	
						2.5	

JSC "PROTON-ELECTROTEX"

19 Leskova, 302027, Orel, RUSSIA, Fax : +7 (4862) 41-00-56 Phones : +7 (4862) 43-41-39 / 43-41-40

E-mail: eletex@eletex.ru / eltex@orel.ru; I-net: www.eletex.ru

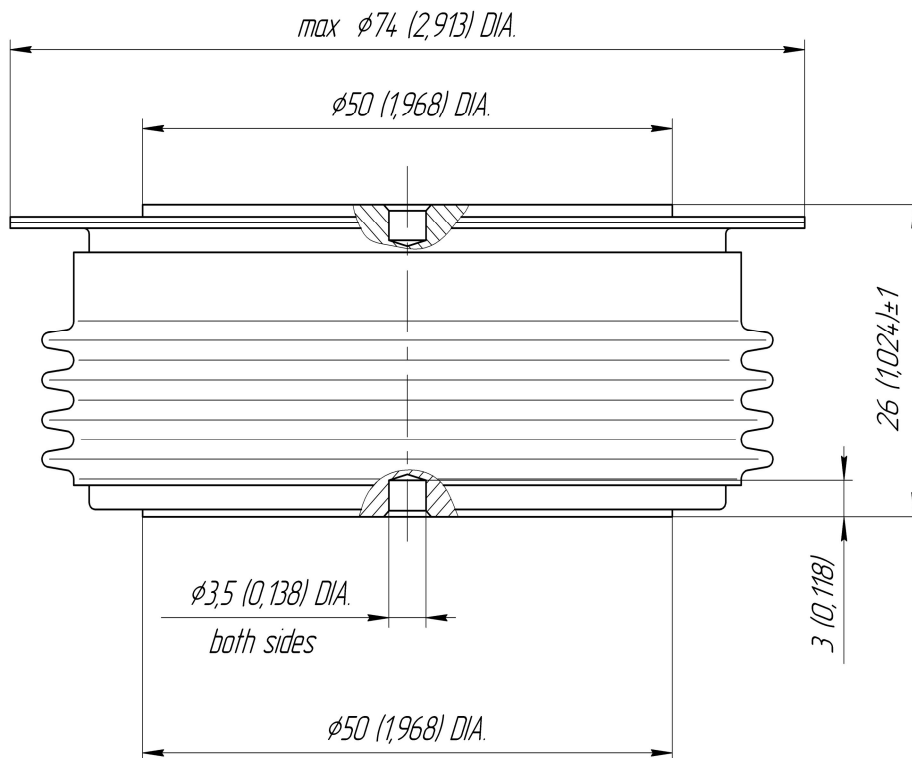

All dimensions in millimeters (inches)

The information contained herein is confidential and protected by Copyright.
In the interest of product improvement, Proton-Electrotex reserves the right to change data sheet without notice.

JSC "PROTON-ELECTROTEX"

19 Leskova, 302027, Orel, RUSSIA, Fax : +7 (4862) 41-00-56 Phones : +7 (4862) 43-41-39 / 43-41-40

E-mail: eletex@eletex.ru / eltex@orel.ru; I-net: www.eletex.ru