



PROTON-ELECTROTEX RUSSIA

High power cycling capability
Low on-state and switching losses
Optimized for line frequency rectifiers
Designed for traction and industrial applications

Power Rectifier Avalanche Diodes Type DA253-1600-28

Average forward current		I_{FAV}		1600 A	
Repetitive peak reverse voltage		V_{RRM}		2000 ÷ 2800 V	
V_{RRM} , V	2000	2200	2400	2600	2800
Voltage code	20	22	24	26	28
T_j , °C	- 60 ÷ 175				

MAXIMUM ALLOWABLE RATINGS

Symbols and parameters		Units	Values	Test conditions	
ON-STATE					
I_{FAV}	Average forward current	A	1600 1795	$T_c=112$ °C; Double side cooled; $T_c=100$ °C; Double side cooled; 180° half-sine wave; 50 Hz	
I_{FRMS}	RMS forward current	A	2512	$T_c=112$ °C; Double side cooled; 180° half-sine wave; 50 Hz	
I_{FSM}	Surge forward current	kA	25.0 29.0	$T_j=T_{j\max}$ $T_j=25$ °C	180° half-sine wave; 50 Hz ($t_p=10$ ms); single pulse; $V_R=0$ V;
			27.0 31.0	$T_j=T_{j\max}$ $T_j=25$ °C	180° half-sine wave; 60 Hz ($t_p=8.3$ ms); single pulse; $V_R=0$ V;
I^2t	Safety factor	$A^2s \cdot 10^3$	3125 4205	$T_j=T_{j\max}$ $T_j=25$ °C	180° half-sine wave; 50 Hz ($t_p=10$ ms); single pulse; $V_R=0$ V;
			3025 3985	$T_j=T_{j\max}$ $T_j=25$ °C	180° half-sine wave; 60 Hz ($t_p=8.3$ ms); single pulse; $V_R=0$ V;
BLOCKING					
V_{RRM}	Repetitive peak reverse voltages	V	2000÷2800	$T_{j\min} < T_j < T_{j\max}$; 180° half-sine wave; 50 Hz;	
V_{RSM}	Non-repetitive peak reverse voltages	V	2100÷2900	$T_{j\min} < T_j < T_{j\max}$; 180° half-sine wave; 50 Hz; single pulse;	
V_R	Reverse continuous voltages	V	$0.75 \cdot V_{RRM}$	$T_j = T_{j\max}$;	
P_{RSM}	Surge reverse power dissipation	kW	16	$T_j = T_{j\max}$; $t_p = 100$ μs; 180° half-sine wave, 50 Hz, single pulse	
THERMAL					
T_{stg}	Storage temperature	°C	- 60 ÷ 175		
T_j	Operating junction temperature	°C	- 60 ÷ 175		
MECHANICAL					
F	Mounting force	kN	24.0 ÷ 28.0		
a	Acceleration	m/s^2	50	Device unclamped	
			100	Device clamped	

JSC "PROTON-ELECTROTEX"

19 Leskova, 302027, Orel, RUSSIA, Fax : +7 (4862) 41-00-56 Phones : +7 (4862) 43-41-39 / 43-41-40

E-mail: eletex@eletex.ru / eltex@orel.ru; I-net: www.eletex.ru

CHARACTERISTICS

Symbols and parameters		Units	Values	Conditions	
ON-STATE					
V_{FM}	Peak forward voltage, max	V	2.10	$T_j=25\text{ }^\circ\text{C}; I_{FM}=5024\text{ A}$	
$V_{F(TO)}$	Forward threshold voltage, max	V	1.00	$T_j=T_{j\text{ max}}$	
r_T	Forward slope resistance, max	m Ω	0.300	$0.5\pi I_{FAV} < I_T < 1.5\pi I_{FAV}$	
BLOCKING					
I_{RRM}	Repetitive peak reverse current, max	mA	100	$T_j=T_{j\text{ max}}$ $V_R=V_{RRM}$	
THERMAL					
R_{thjc}	Thermal resistance, junction to case, max	$^\circ\text{C/W}$	0.0180	Direct current	Double side cooled
R_{thjc-A}			0.0396		Anode side cooled
R_{thjc-K}			0.0324		Cathode side cooled
R_{thck}	Thermal resistance, case to heatsink, max	$^\circ\text{C/W}$	0.0040	Direct current	
MECHANICAL					
w	Weight, typ	g	510		
D_s	Surface creepage distance	mm (inch)	38.84 (1.529)		
D_a	Air strike distance	mm (inch)	22.50 (0.886)		

PART NUMBERING GUIDE

DA	253	1600	28	N
1	2	3	4	5

1. DA — Avalanche Diode
2. Design version
3. Average forward current, A
4. Voltage code
5. Ambient conditions: N – normal; T – tropical

JSC "PROTON-ELECTROTEX"

19 Leskova, 302027, Orel, RUSSIA, Fax : +7 (4862) 41-00-56 Phones : +7 (4862) 43-41-39 / 43-41-40

E-mail: eletex@eletex.ru / eltex@orel.ru; I-net: www.eletex.ru

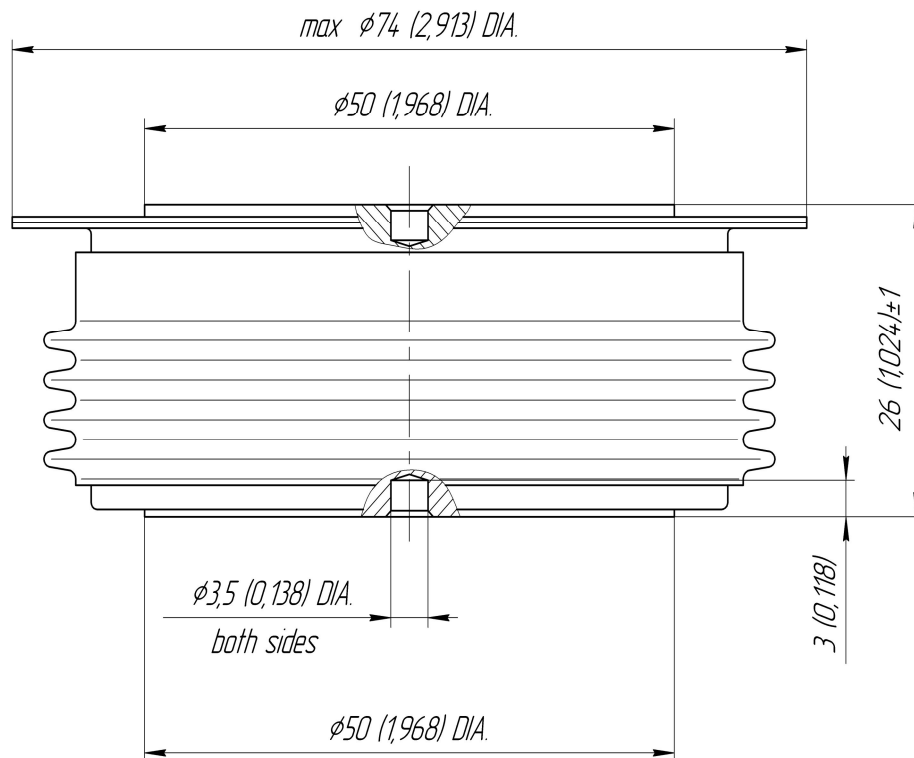

All dimensions in millimeters (inches)

The information contained herein is confidential and protected by Copyright.
In the interest of product improvement, Proton-Electrotex reserves the right to change data sheet without notice.

JSC "PROTON-ELECTROTEX"

19 Leskova, 302027, Orel, RUSSIA, Fax : +7 (4862) 41-00-56 Phones : +7 (4862) 43-41-39 / 43-41-40

E-mail: eletex@eletex.ru / eltex@orel.ru; I-net: www.eletex.ru