



High power cycling capability
Low on-state and switching losses
Optimized for line frequency rectifiers
Designed for traction and industrial applications

**Power Rectifier
Avalanche Diodes
Type DA173-5000-18**

Average forward current		I_{FAV}		5000 A	
Repetitive peak reverse voltage		V_{RRM}		1000 ÷ 1800 V	
V_{RRM} , V	1000	1200	1400	1600	1800
Voltage code	10	12	14	16	18
T_{ij} , °C	- 60 ÷ 175				

MAXIMUM ALLOWABLE RATINGS

Symbols and parameters		Units	Values	Test conditions	
ON-STATE					
I_{FAV}	Average forward current	A	5000 4480	$T_c=84$ °C; Double side cooled; $T_c=100$ °C; Double side cooled; 180° half-sine wave; 50 Hz	
I_{FRMS}	RMS forward current	A	7850	$T_c=84$ °C; Double side cooled; 180° half-sine wave; 50 Hz	
I_{FSM}	Surge forward current	kA	60.0 69.0	$T_j=T_{jmax}$ $T_j=25$ °C	180° half-sine wave; 50 Hz ($t_p=10$ ms); single pulse; $V_R=0$ V;
			63.0 72.0	$T_j=T_{jmax}$ $T_j=25$ °C	180° half-sine wave; 60 Hz ($t_p=8.3$ ms); single pulse; $V_R=0$ V;
I^2t	Safety factor	$A^2s \cdot 10^3$	18000 23805	$T_j=T_{jmax}$ $T_j=25$ °C	180° half-sine wave; 50 Hz ($t_p=10$ ms); single pulse; $V_R=0$ V;
			16470 21510	$T_j=T_{jmax}$ $T_j=25$ °C	180° half-sine wave; 60 Hz ($t_p=8.3$ ms); single pulse; $V_R=0$ V;
BLOCKING					
V_{RRM}	Repetitive peak reverse voltages	V	1000÷1800	$T_{jmin} < T_j < T_{jmax}$; 180° half-sine wave; 50 Hz;	
V_{RSM}	Non-repetitive peak reverse voltages	V	1100÷1900	$T_{jmin} < T_j < T_{jmax}$; 180° half-sine wave; 50 Hz; single pulse;	
V_R	Reverse continuous voltages	V	$0.75 \cdot V_{RRM}$	$T_j=T_{jmax}$;	
P_{RSM}	Surge reverse power dissipation	kW	16	$T_j=T_{jmax}$; $t_p = 100$ μs; 180° half-sine wave, 50 Hz, single pulse	
THERMAL					
T_{stg}	Storage temperature	°C	- 60 ÷ 175		
T_j	Operating junction temperature	°C	- 60 ÷ 175		
MECHANICAL					
F	Mounting force	kN	40.0 ÷ 50.0		
a	Acceleration	m/s^2	50	Device unclamped	
			100	Device clamped	

JSC "PROTON-ELECTROTEX"

19 Leskova, 302027, Orel, RUSSIA, Fax : +7 (4862) 41-00-56 Phones : +7 (4862) 43-41-39 / 43-41-40

E-mail: eletex@eletex.ru / eltex@orel.ru; I-net: www.eletex.ru

CHARACTERISTICS

Symbols and parameters		Units	Values	Conditions	
ON-STATE					
V_{FM}	Peak forward voltage, max	V	2.00	$T_j=25\text{ }^\circ\text{C}; I_{FM}=12560\text{ A}$	
$V_{F(TO)}$	Forward threshold voltage, max	V	0.60	$T_j=T_{j\text{ max}}$	
r_T	Forward slope resistance, max	m Ω	0.125	$0.5\pi I_{FAV} < I_T < 1.5\pi I_{FAV}$	
BLOCKING					
I_{RRM}	Repetitive peak reverse current, max	mA	100	$T_j=T_{j\text{ max}}$ $V_R=V_{RRM}$	
THERMAL					
R_{thjc}	Thermal resistance, junction to case, max	$^\circ\text{C/W}$	0.0085	Direct current	Double side cooled
R_{thjc-A}			0.0187		Anode side cooled
R_{thjc-K}			0.0153		Cathode side cooled
R_{thck}	Thermal resistance, case to heatsink, max	$^\circ\text{C/W}$	0.0020	Direct current	
MECHANICAL					
w	Weight, typ	g	1500		
D_s	Surface creepage distance	mm (inch)	41.40 (1.630)		
D_a	Air strike distance	mm (inch)	23.10 (0.909)		

PART NUMBERING GUIDE

DA	173	5000	18	N
1	2	3	4	5

1. DA — Avalanche Diode
2. Design version
3. Average forward current, A
4. Voltage code
5. Ambient conditions: N – normal; T – tropical

JSC "PROTON-ELECTROTEX"

19 Leskova, 302027, Orel, RUSSIA, Fax : +7 (4862) 41-00-56 Phones : +7 (4862) 43-41-39 / 43-41-40

E-mail: eletex@eletex.ru / eltex@orel.ru; I-net: www.eletex.ru

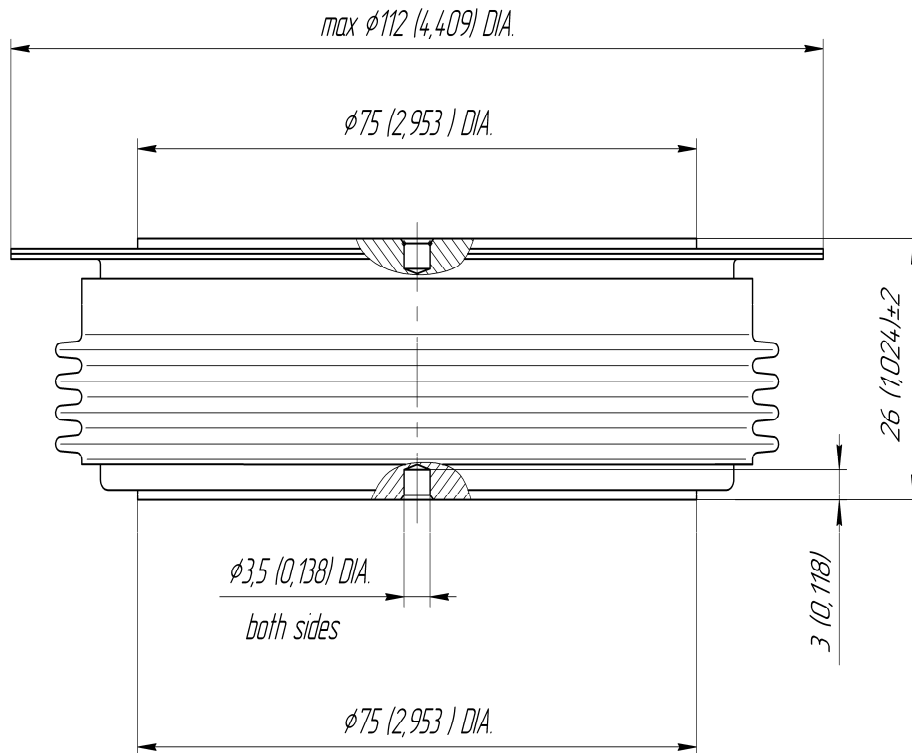

All dimensions in millimeters (inches)

The information contained herein is confidential and protected by Copyright.
 In the interest of product improvement, Proton-Electrotex reserves the right to change data sheet without notice.

JSC "PROTON-ELECTROTEX"

19 Leskova, 302027, Orel, RUSSIA, Fax : +7 (4862) 41-00-56 Phones : +7 (4862) 43-41-39 / 43-41-40

E-mail: eletex@eletex.ru / eltex@orel.ru; I-net: www.eletex.ru