



High power cycling capability
Low on-state and switching losses
Optimized for line frequency rectifiers
Designed for traction and industrial applications

Rectifier Diode
Type D443-800-44

Average forward current		I_{FAV}	800 A	
Repetitive peak reverse voltage		V_{RRM}	3800 ÷ 4400 V	
V_{RRM} , V	3800	4000	4200	4400
Voltage code	38	40	42	44
T_j , °C	-60 ÷ 150			

MAXIMUM ALLOWABLE RATINGS

Symbols and parameters		Units	Values	Test conditions
ON-STATE				
I_{FAV}	Average forward current	A	800 745	$T_c=94$ °C; Double side cooled; $T_c=100$ °C; Double side cooled; 180° half-sine wave; 50 Hz
I_{FRMS}	RMS forward current	A	1256	$T_c=94$ °C; Double side cooled; 180° half-sine wave; 50 Hz
I_{FSM}	Surge forward current	kA	12.5 14.0	$T_j=T_{j\ max}$ $T_j=25$ °C 180° half-sine wave; 50 Hz ($t_p=10$ ms); single pulse; $V_R=0$ V;
			14.0 16.0	$T_j=T_{j\ max}$ $T_j=25$ °C 180° half-sine wave; 60 Hz ($t_p=8.3$ ms); single pulse; $V_R=0$ V;
I^2t	Safety factor	$A^2s \cdot 10^3$	780 980	$T_j=T_{j\ max}$ $T_j=25$ °C 180° half-sine wave; 50 Hz ($t_p=10$ ms); single pulse; $V_R=0$ V;
			810 1060	$T_j=T_{j\ max}$ $T_j=25$ °C 180° half-sine wave; 60 Hz ($t_p=8.3$ ms); single pulse; $V_R=0$ V;
BLOCKING				
V_{RRM}	Repetitive peak reverse voltages	V	3800 ÷ 4400	$T_{j\ min} < T_j < T_{j\ max}$; 180° half-sine wave; 50 Hz;
V_{RSM}	Non-repetitive peak reverse voltages	V	3900 ÷ 4500	$T_{j\ min} < T_j < T_{j\ max}$; 180° half-sine wave; 50 Hz; single pulse;
V_R	Reverse continuous voltages	V	$0.75 \cdot V_{RRM}$	$T_j = T_{j\ max}$;
THERMAL				
T_{stg}	Storage temperature	°C	-60 ÷ 150	
T_j	Operating junction temperature	°C	-60 ÷ 150	
MECHANICAL				
F	Mounting force	kN	14.0 ÷ 16.0	
a	Acceleration	m/s^2	50	Device unclamped
			100	Device clamped

CHARACTERISTICS

Symbols and parameters		Units	Values	Conditions	
ON-STATE					
V_{FM}	Peak forward voltage, max	V	1.95	$T_j=25\text{ }^\circ\text{C}; I_{FM}=2512\text{ A}$	
$V_{F(TO)}$	Forward threshold voltage, max	V	1.00	$T_j=T_{j\text{ max}};$	
r_T	Forward slope resistance, max	m Ω	0.500	$0.5\pi I_{FAV} < I_T < 1.5\pi I_{FAV}$	
BLOCKING					
I_{RRM}	Repetitive peak reverse current, max	mA	70	$T_j=T_{j\text{ max}};$ $V_R=V_{RRM}$	
THERMAL					
R_{thjc}	Thermal resistance, junction to case, max	$^\circ\text{C/W}$	0.035	Direct current	Double side cooled
R_{thjc-A}			0.077		Anode side cooled
R_{thjc-K}			0.063		Cathode side cooled
R_{thck}	Thermal resistance, case to heatsink, max	$^\circ\text{C/W}$	0.006	Direct current	
MECHANICAL					
w	Weight, typ	g	280		
D_s	Surface creepage distance	mm (inch)	33.30 (1.311)		
D_a	Air strike distance	mm (inch)	22.50 (0.886)		

PART NUMBERING GUIDE

D	443	800	44	N
1	2	3	4	5

1. D — Rectifier Diode
2. Design version
3. Average forward current, A
4. Voltage code
5. Ambient conditions: N – normal; T – tropical

JSC "PROTON-ELECTROTEX"

19 Leskova, 302027, Orel, RUSSIA, Fax : +7 (4862) 41-00-56 Phones : +7 (4862) 43-41-39 / 43-41-40

E-mail: eletex@eletex.ru / eltex@orel.ru; I-net: www.eletex.ru

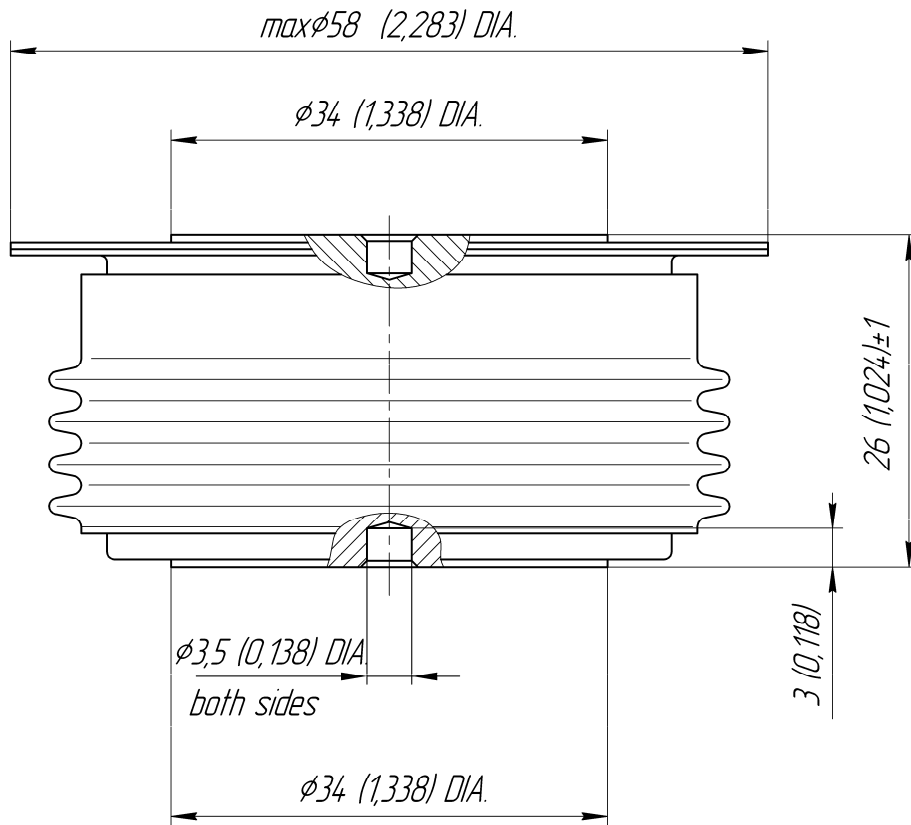

All dimensions in millimeters (inches)

The information contained herein is confidential and protected by Copyright.
 In the interest of product improvement, Proton-Electrotex reserves the right to change data sheet without notice.

JSC "PROTON-ELECTROTEX"

19 Leskova, 302027, Orel, RUSSIA, Fax : +7 (4862) 41-00-56 Phones : +7 (4862) 43-41-39 / 43-41-40

E-mail: eletex@eletex.ru / eltex@orel.ru; I-net: www.eletex.ru