



High power cycling capability
Low on-state and switching losses
Optimized for line frequency rectifiers
Designed for traction and industrial applications

Rectifier Diode
Type D173-3200-36

Average forward current		I_{FAV}	3200 A	
Repetitive peak reverse voltage		V_{RRM}	3000 ÷ 3600 V	
V_{RRM} , V	3000	3200	3400	3600
Voltage code	30	32	34	36
T_j , °C	-60 ÷ 160			

MAXIMUM ALLOWABLE RATINGS

Symbols and parameters		Units	Values	Test conditions
ON-STATE				
I_{FAV}	Average forward current	A	3200 4240	$T_c=109$ °C; Double side cooled; $T_c=85$ °C; Double side cooled; 180° half-sine wave; 50 Hz
I_{FRMS}	RMS forward current	A	5024	$T_c=109$ °C; Double side cooled; 180° half-sine wave; 50 Hz
I_{FSM}	Surge forward current	kA	50.0 58.0	$T_j=T_{j\max}$ $T_j=25$ °C 180° half-sine wave; 50 Hz ($t_p=10$ ms); single pulse; $V_R=0$ V;
			53.0 61.0	$T_j=T_{j\max}$ $T_j=25$ °C 180° half-sine wave; 60 Hz ($t_p=8.3$ ms); single pulse; $V_R=0$ V;
I^2t	Safety factor	$A^2s \cdot 10^3$	12500 16820	$T_j=T_{j\max}$ $T_j=25$ °C 180° half-sine wave; 50 Hz ($t_p=10$ ms); single pulse; $V_R=0$ V;
			11655 15440	$T_j=T_{j\max}$ $T_j=25$ °C 180° half-sine wave; 60 Hz ($t_p=8.3$ ms); single pulse; $V_R=0$ V;
BLOCKING				
V_{RRM}	Repetitive peak reverse voltages	V	3000 ÷ 3600	$T_{j\min} < T_j < T_{j\max}$; 180° half-sine wave; 50 Hz;
V_{RSM}	Non-repetitive peak reverse voltages	V	3100 ÷ 3700	$T_{j\min} < T_j < T_{j\max}$; 180° half-sine wave; 50 Hz; single pulse;
V_R	Reverse continuous voltages	V	$0.75 \cdot V_{RRM}$	$T_j = T_{j\max}$;
THERMAL				
T_{stg}	Storage temperature	°C	-60 ÷ 160	
T_j	Operating junction temperature	°C	-60 ÷ 160	
MECHANICAL				
F	Mounting force	kN	40 ÷ 50	
a	Acceleration	m/s^2	50	Device unclamped
			100	Device clamped

JSC "PROTON-ELECTROTEX"

19 Leskova, 302027, Orel, RUSSIA, Fax : +7 (4862) 41-00-56 Phones : +7 (4862) 43-41-39 / 43-41-40

E-mail: eletex@eletex.ru / eltex@orel.ru; I-net: www.eletex.ru

CHARACTERISTICS

Symbols and parameters		Units	Values	Conditions	
ON-STATE					
V_{FM}	Peak forward voltage, max	V	1.80	$T_j=25\text{ }^\circ\text{C}; I_{FM}=10048\text{ A}$	
$V_{F(TO)}$	Forward threshold voltage, max	V	1.25	$T_j=T_{j\text{ max}};$ $0.5 \pi I_{FAV} < I_T < 1.5 \pi I_{FAV}$	
r_T	Forward slope resistance, max	m Ω	0.080		
BLOCKING					
I_{RRM}	Repetitive peak reverse current, max	mA	150	$T_j=T_{j\text{ max}};$ $V_R=V_{RRM}$	
SWITCHING					
Q_{rr}	Total recovered charge, max	μC	6750	$T_j=T_{j\text{ max}}; I_{TM}=2000\text{ A};$ $di_R/dt=-5\text{ A}/\mu\text{s};$ $V_R=100\text{ V}$	
t_{rr}	Reverse recovery time, max	μs	75		
I_{rrM}	Peak reverse recovery current, max	A	180		
THERMAL					
R_{thjc}	Thermal resistance, junction to case, max	$^\circ\text{C}/\text{W}$	0.0085	Direct current	Double side cooled
R_{thjc-A}			0.0187		Anode side cooled
R_{thjc-K}			0.0153		Cathode side cooled
R_{thck}	Thermal resistance, case to heatsink, max	$^\circ\text{C}/\text{W}$	0.0020	Direct current	
MECHANICAL					
w	Weight, typ	g	1500		
D_s	Surface creepage distance	mm (inch)	41.40 (1.630)		
D_a	Air strike distance	mm (inch)	23.10 (0.909)		

PART NUMBERING GUIDE

D	173	3200	36	N
1	2	3	4	5

1. D — Rectifier Diode
2. Design version
3. Average forward current, A
4. Voltage code
5. Ambient conditions: N – normal; T – tropical

JSC "PROTON-ELECTROTEX"

19 Leskova, 302027, Orel, RUSSIA, Fax : +7 (4862) 41-00-56 Phones : +7 (4862) 43-41-39 / 43-41-40

E-mail: eletex@eletex.ru / eltex@orel.ru; I-net: www.eletex.ru

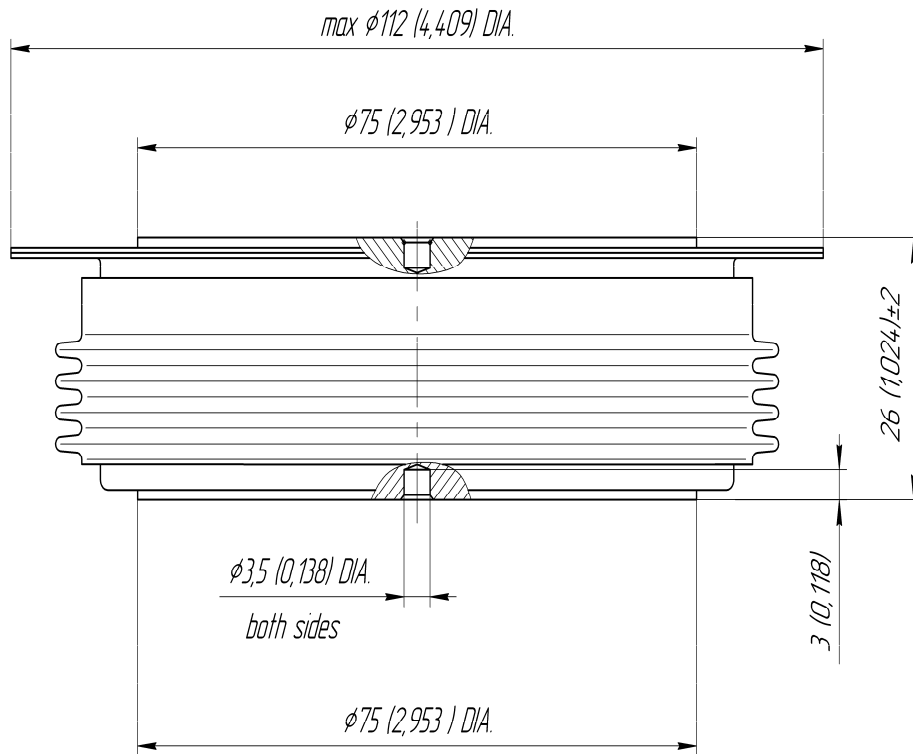

All dimensions in millimeters (inches)

The information contained herein is confidential and protected by Copyright.
 In the interest of product improvement, Proton-Electrotex reserves the right to change data sheet without notice.

JSC "PROTON-ELECTROTEX"

19 Leskova, 302027, Orel, RUSSIA, Fax : +7 (4862) 41-00-56 Phones : +7 (4862) 43-41-39 / 43-41-40

E-mail: eletex@eletex.ru / eltex@orel.ru; I-net: www.eletex.ru