



High power cycling capability  
Low on-state and switching losses  
Optimized for line frequency rectifiers  
Designed for traction and industrial applications

**Rectifier Diode**  
**Type D173-2500-44**

Average forward current		$I_{FAV}$	2500 A	
Repetitive peak reverse voltage		$V_{RRM}$	3800 ÷ 4400 V	
$V_{RRM}$ , V	3800	4000	4200	4400
Voltage code	38	40	42	44
$T_j$ , °C	-60 ÷ 150			

**MAXIMUM ALLOWABLE RATINGS**

Symbols and parameters		Units	Values	Test conditions
<b>ON-STATE</b>				
$I_{FAV}$	Average forward current	A	2500 3270	$T_c=116$ °C; Double side cooled; $T_c=100$ °C; Double side cooled; 180° half-sine wave; 50 Hz
$I_{FRMS}$	RMS forward current	A	3925	$T_c=116$ °C; Double side cooled; 180° half-sine wave; 50 Hz
$I_{FSM}$	Surge forward current	kA	40.0 46.0	$T_j=T_{j\max}$ $T_j=25$ °C 180° half-sine wave; 50 Hz ( $t_p=10$ ms); single pulse; $V_R=0$ V;
			42.0 48.3	$T_j=T_{j\max}$ $T_j=25$ °C 180° half-sine wave; 60 Hz ( $t_p=8.3$ ms); single pulse; $V_R=0$ V;
$I^2t$	Safety factor	$A^2s \cdot 10^3$	8000 10580	$T_j=T_{j\max}$ $T_j=25$ °C 180° half-sine wave; 50 Hz ( $t_p=10$ ms); single pulse; $V_R=0$ V;
			7321 9681	$T_j=T_{j\max}$ $T_j=25$ °C 180° half-sine wave; 60 Hz ( $t_p=8.3$ ms); single pulse; $V_R=0$ V;
<b>BLOCKING</b>				
$V_{RRM}$	Repetitive peak reverse voltages	V	3800 ÷ 4400	$T_{j\min} < T_j < T_{j\max}$ ; 180° half-sine wave; 50 Hz;
$V_{RSM}$	Non-repetitive peak reverse voltages	V	3900 ÷ 4500	$T_{j\min} < T_j < T_{j\max}$ ; 180° half-sine wave; 50 Hz; single pulse;
$V_R$	Reverse continuous voltages	V	$0.75 \cdot V_{RRM}$	$T_j = T_{j\max}$ ;
<b>THERMAL</b>				
$T_{stg}$	Storage temperature	°C	-60 ÷ 150	
$T_j$	Operating junction temperature	°C	-60 ÷ 150	
<b>MECHANICAL</b>				
F	Mounting force	kN	40 ÷ 50	
a	Acceleration	$m/s^2$	50	Device unclamped
			100	Device clamped

**JSC "PROTON-ELECTROTEX"**

19 Leskova, 302027, Orel, RUSSIA, Fax : +7 (4862) 41-00-56 Phones : +7 (4862) 43-41-39 / 43-41-40

E-mail: [eletex@eletex.ru](mailto:eletex@eletex.ru) / [eltex@orel.ru](mailto:eltex@orel.ru); I-net: [www.eletex.ru](http://www.eletex.ru)

## CHARACTERISTICS

Symbols and parameters		Units	Values	Conditions	
<b>ON-STATE</b>					
$V_{FM}$	Peak forward voltage, max	V	1.80	$T_j=25\text{ }^\circ\text{C}; I_{FM}=7850\text{ A}$	
$V_{F(TO)}$	Forward threshold voltage, max	V	0.80	$T_j=T_{j\text{ max}};$	
$r_T$	Forward slope resistance, max	m $\Omega$	0.125	$0.5\pi I_{FAV} < I_T < 1.5\pi I_{FAV}$	
<b>BLOCKING</b>					
$I_{RRM}$	Repetitive peak reverse current, max	mA	150	$T_j=T_{j\text{ max}};$ $V_R=V_{RRM}$	
<b>SWITCHING</b>					
$Q_{rr}$	Total recovered charge, max	$\mu\text{C}$	7650	$T_j=T_{j\text{ max}}; I_{TM}=2000\text{ A};$	
$t_{rr}$	Reverse recovery time, max	$\mu\text{s}$	85	$di_R/dt=-5\text{ A}/\mu\text{s};$	
$I_{rrM}$	Peak reverse recovery current, max	A	180	$V_R=100\text{ V};$	
<b>THERMAL</b>					
$R_{thjc}$	Thermal resistance, junction to case, max	$^\circ\text{C}/\text{W}$	0.0085	Direct current	Double side cooled
$R_{thjc-A}$			0.0187		Anode side cooled
$R_{thjc-K}$			0.0153		Cathode side cooled
$R_{thck}$	Thermal resistance, case to heatsink, max	$^\circ\text{C}/\text{W}$	0.0020	Direct current	
<b>MECHANICAL</b>					
w	Weight, typ	g	1500		
$D_s$	Surface creepage distance	mm (inch)	41.40 (1.630)		
$D_a$	Air strike distance	mm (inch)	23.10 (0.909)		

### PART NUMBERING GUIDE

D	173	2500	44	N
1	2	3	4	5

1. D — Rectifier Diode
2. Design version
3. Average forward current, A
4. Voltage code
5. Ambient conditions: N – normal; T – tropical

### JSC "PROTON-ELECTROTEX"

19 Leskova, 302027, Orel, RUSSIA, Fax : +7 (4862) 41-00-56 Phones : +7 (4862) 43-41-39 / 43-41-40

E-mail: [eletex@eletex.ru](mailto:eletex@eletex.ru) / [eltex@orel.ru](mailto:eltex@orel.ru); I-net: [www.eletex.ru](http://www.eletex.ru)

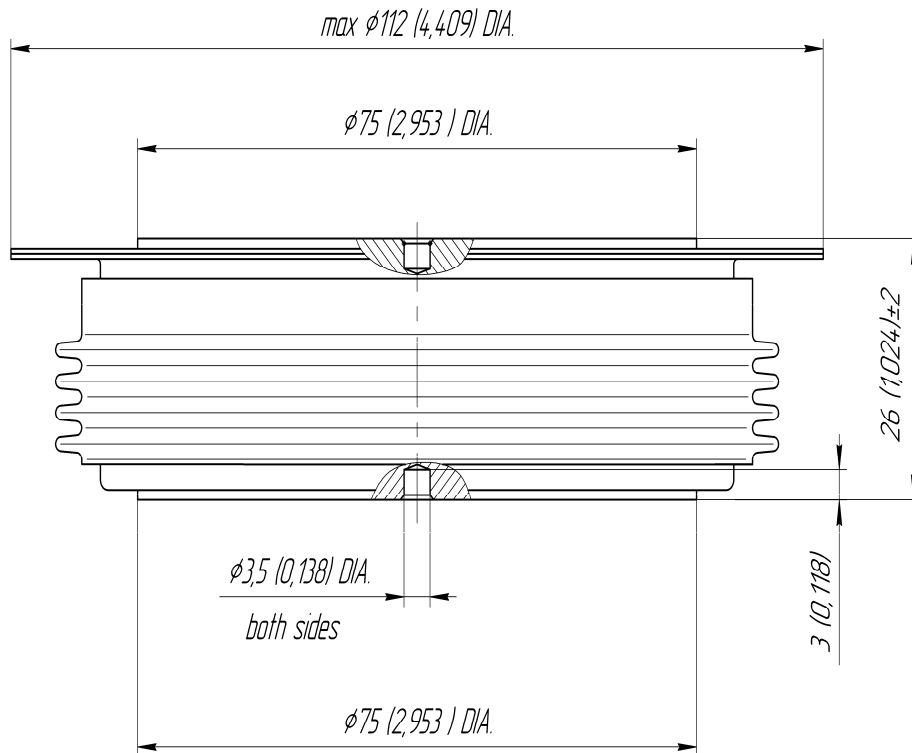

All dimensions in millimeters (inches)

The information contained herein is confidential and protected by Copyright.  
 In the interest of product improvement, Proton-Electrotex reserves the right to change data sheet without notice.

**JSC "PROTON-ELECTROTEX"**

19 Leskova, 302027, Orel, RUSSIA, Fax : +7 (4862) 41-00-56 Phones : +7 (4862) 43-41-39 / 43-41-40

E-mail: [eletex@eletex.ru](mailto:eletex@eletex.ru) / [eltex@orel.ru](mailto:eltex@orel.ru); I-net: [www.eletex.ru](http://www.eletex.ru)