



PROTON-ELECTROTEX RUSSIA

High power cycling capability
Low on-state and switching losses
Optimized for line frequency rectifiers
Designed for traction and industrial applications

Rectifier Diode Type D133-630-28

Average forward current		I_{FAV}	630 A		
Repetitive peak reverse voltage		V_{RRM}	2000 ÷ 2800 V		
V_{RRM}, V	2000	2200	2400	2600	2800
Voltage code	20	22	24	26	28
$T_j, °C$	-60 ÷ 175				

MAXIMUM ALLOWABLE RATINGS

Symbols and parameters		Units	Values	Test conditions
ON-STATE				
I_{FAV}	Average forward current	A	630 970	$T_c=133 °C$; Double side cooled; $T_c=100 °C$; Double side cooled; 180° half-sine wave; 50 Hz
I_{FRMS}	RMS forward current	A	989	$T_c=133 °C$; Double side cooled; 180° half-sine wave; 50 Hz
I_{FSM}	Surge forward current	kA	12.0 14.0	$T_j=T_{j max}$ $T_j=25 °C$ 180° half-sine wave; 50 Hz ($t_p=10 ms$); single pulse; $V_R=0 V$;
			13.0 15.0	$T_j=T_{j max}$ $T_j=25 °C$ 180° half-sine wave; 60 Hz ($t_p=8.3 ms$); single pulse; $V_R=0 V$;
I^2t	Safety factor	$A^2s \cdot 10^3$	720 980	$T_j=T_{j max}$ $T_j=25 °C$ 180° half-sine wave; 50 Hz ($t_p=10 ms$); single pulse; $V_R=0 V$;
			700 930	$T_j=T_{j max}$ $T_j=25 °C$ 180° half-sine wave; 60 Hz ($t_p=8.3 ms$); single pulse; $V_R=0 V$;
BLOCKING				
V_{RRM}	Repetitive peak reverse voltages	V	2000 ÷ 2800	$T_{j min} < T_j < T_{j max}$; 180° half-sine wave; 50 Hz;
V_{RSM}	Non-repetitive peak reverse voltages	V	2100 ÷ 2900	$T_{j min} < T_j < T_{j max}$; 180° half-sine wave; 50 Hz; single pulse;
V_R	Reverse continuous voltages	V	$0.75 \cdot V_{RRM}$	$T_j = T_{j max}$;
THERMAL				
T_{stg}	Storage temperature	°C	-60 ÷ 175	
T_j	Operating junction temperature	°C	-60 ÷ 175	
MECHANICAL				
F	Mounting force	kN	9.0 ÷ 11.0	
a	Acceleration	m/s^2	50	Device unclamped
			100	Device clamped

JSC "PROTON-ELECTROTEX"

19 Leskova, 302027, Orel, RUSSIA, Fax : +7 (4862) 41-00-56 Phones : +7 (4862) 43-41-39 / 43-41-40

E-mail: eletex@eletex.ru / eltex@orel.ru; I-net: www.eletex.ru

CHARACTERISTICS

Symbols and parameters		Units	Values	Conditions	
ON-STATE					
V_{FM}	Peak forward voltage, max	V	1.60	$T_j=25\text{ }^\circ\text{C}; I_{FM}=1978\text{ A}$	
$V_{F(TO)}$	Forward threshold voltage, max	V	1.10	$T_j=T_{j\text{ max}}$	
r_T	Forward slope resistance, max	m Ω	0.350	$0.5\pi I_{FAV} < I_T < 1.5\pi I_{FAV}$	
BLOCKING					
I_{RRM}	Repetitive peak reverse current, max	mA	50	$T_j=T_{j\text{ max}};$ $V_R=V_{RRM}$	
THERMAL					
R_{thjc}	Thermal resistance, junction to case, max	$^\circ\text{C/W}$	0.040	Direct current	Double side cooled
R_{thjc-A}			0.088		Anode side cooled
R_{thjc-K}			0.072		Cathode side cooled
R_{thck}	Thermal resistance, case to heatsink, max	$^\circ\text{C/W}$	0.008	Direct current	
MECHANICAL					
w	Weight, typ	g	180		
D_s	Surface creepage distance	mm (inch)	23.69 (0.933)		
D_a	Air strike distance	mm (inch)	19.10 (0.752)		

PART NUMBERING GUIDE

D	133	630	28	N
1	2	3	4	5

1. D — Rectifier Diode
2. Design version
3. Average forward current, A
4. Voltage code
5. Ambient conditions: N – normal; T – tropical

JSC "PROTON-ELECTROTEX"

19 Leskova, 302027, Orel, RUSSIA, Fax : +7 (4862) 41-00-56 Phones : +7 (4862) 43-41-39 / 43-41-40

E-mail: eletex@eletex.ru / eltex@orel.ru; I-net: www.eletex.ru

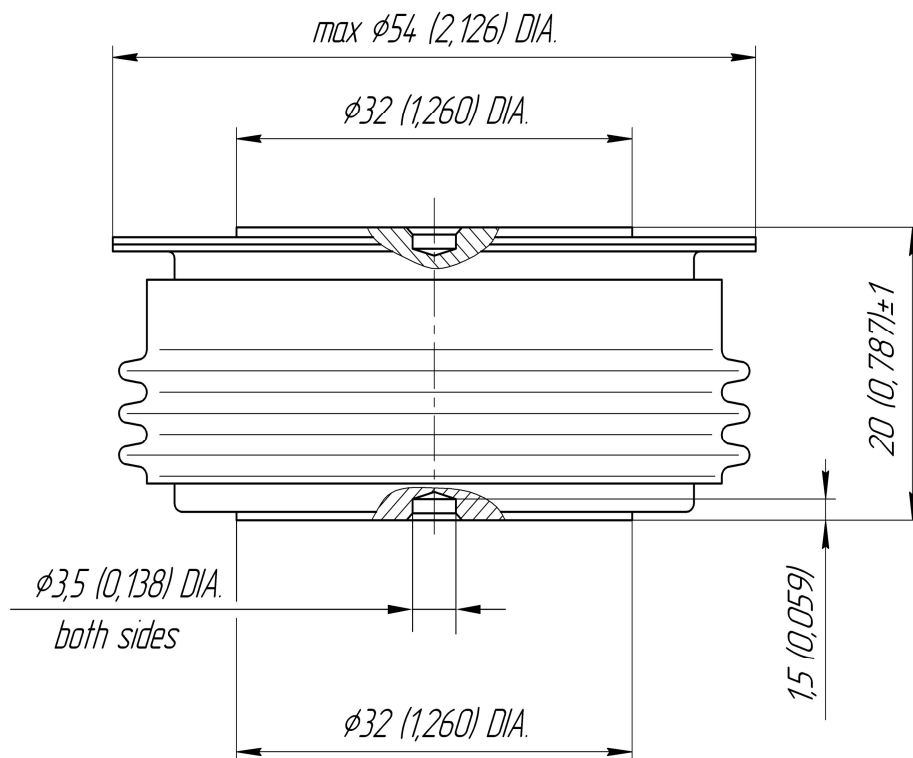

All dimensions in millimeters (inches)

The information contained herein is confidential and protected by Copyright.
 In the interest of product improvement, Proton-Electrotex reserves the right to change data sheet without notice.

JSC "PROTON-ELECTROTEX"

19 Leskova, 302027, Orel, RUSSIA, Fax : +7 (4862) 41-00-56 Phones : +7 (4862) 43-41-39 / 43-41-40

E-mail: eletex@eletex.ru / eltex@orel.ru; I-net: www.eletex.ru