



# PROTON-ELECTROTEX RUSSIA

High power cycling capability  
Low on-state and switching losses  
Optimized for line frequency rectifiers  
Designed for traction and industrial applications

## Rectifier Diode Type D123-500-18

Average forward current		$I_{FAV}$	500 A		
Repetitive peak reverse voltage		$V_{RRM}$	1000 ÷ 1800 V		
$V_{RRM}, V$	1000	1200	1400	1600	1800
Voltage code	10	12	14	16	18
$T_{jv}, ^\circ C$	-60 ÷ 190				

### MAXIMUM ALLOWABLE RATINGS

Symbols and parameters		Units	Values	Test conditions
<b>ON-STATE</b>				
$I_{FAV}$	Average forward current	A	500 720	$T_c=137\ ^\circ C$ ; Double side cooled; $T_c=100\ ^\circ C$ ; Double side cooled; 180° half-sine wave; 50 Hz
$I_{FRMS}$	RMS forward current	A	785	$T_c=137\ ^\circ C$ ; Double side cooled; 180° half-sine wave; 50 Hz
$I_{FSM}$	Surge forward current	kA	7.5 8.6	$T_j=T_{j\ max}$ $T_j=25\ ^\circ C$ 180° half-sine wave; 50 Hz ( $t_p=10\ ms$ ); single pulse; $V_R=0\ V$ ;
			8.0 9.2	$T_j=T_{j\ max}$ $T_j=25\ ^\circ C$ 180° half-sine wave; 60 Hz ( $t_p=8.3\ ms$ ); single pulse; $V_R=0\ V$ ;
$I^2t$	Safety factor	$A^2s \cdot 10^3$	280 365	$T_j=T_{j\ max}$ $T_j=25\ ^\circ C$ 180° half-sine wave; 50 Hz ( $t_p=10\ ms$ ); single pulse; $V_R=0\ V$ ;
			265 350	$T_j=T_{j\ max}$ $T_j=25\ ^\circ C$ 180° half-sine wave; 60 Hz ( $t_p=8.3\ ms$ ); single pulse; $V_R=0\ V$ ;
<b>BLOCKING</b>				
$V_{RRM}$	Repetitive peak reverse voltages	V	1000 ÷ 1800	$T_{j\ min} < T_j < T_{j\ max}$ ; 180° half-sine wave; 50 Hz;
$V_{RSM}$	Non-repetitive peak reverse voltages	V	1100 ÷ 1900	$T_{j\ min} < T_j < T_{j\ max}$ ; 180° half-sine wave; 50 Hz; single pulse;
$V_R$	Reverse continuous voltages	V	$0.75 \cdot V_{RRM}$	$T_j = T_{j\ max}$ ;
<b>THERMAL</b>				
$T_{stg}$	Storage temperature	$^\circ C$	-60 ÷ 190	
$T_j$	Operating junction temperature	$^\circ C$	-60 ÷ 190	
<b>MECHANICAL</b>				
F	Mounting force	kN	5.0 ÷ 7.0	
a	Acceleration	$m/s^2$	50	Device unclamped
			100	Device clamped

#### JSC "PROTON-ELECTROTEX"

19 Leskova, 302027, Orel, RUSSIA, Fax : +7 (4862) 41-00-56 Phones : +7 (4862) 43-41-39 / 43-41-40

E-mail: [eletex@eletex.ru](mailto:eletex@eletex.ru) / [eltex@orel.ru](mailto:eltex@orel.ru); I-net: [www.eletex.ru](http://www.eletex.ru)

## CHARACTERISTICS

Symbols and parameters		Units	Values	Conditions	
<b>ON-STATE</b>					
$V_{FM}$	Peak forward voltage, max	V	1.55	$T_j=25\text{ }^\circ\text{C}; I_{FM}=1570\text{ A}$	
$V_{F(TO)}$	Forward threshold voltage, max	V	0.90	$T_j=T_{j\text{ max}};$	
$r_T$	Forward slope resistance, max	m $\Omega$	0.500	$0.5\pi I_{FAV} < I_T < 1.5\pi I_{FAV}$	
<b>BLOCKING</b>					
$I_{RRM}$	Repetitive peak reverse current, max	mA	35	$T_j=T_{j\text{ max}};$ $V_R=V_{RRM}$	
<b>THERMAL</b>					
$R_{thjc}$	Thermal resistance, junction to case, max	$^\circ\text{C/W}$	0.070	Direct current	Double side cooled
$R_{thjc-A}$			0.154		Anode side cooled
$R_{thjc-K}$			0.126		Cathode side cooled
$R_{thck}$	Thermal resistance, case to heatsink, max	$^\circ\text{C/W}$	0.010	Direct current	
<b>MECHANICAL</b>					
w	Weight, typ	g	65		
$D_s$	Surface creepage distance	mm (inch)	11.74 (0.462)		
$D_a$	Air strike distance	mm (inch)	11.60 (0.457)		

### PART NUMBERING GUIDE

D	123	500	18	N
1	2	3	4	5

1. D — Rectifier Diode
2. Design version
3. Average forward current, A
4. Voltage code
5. Ambient conditions: N – normal; T – tropical

### JSC "PROTON-ELECTROTEX"

19 Leskova, 302027, Orel, RUSSIA, Fax : +7 (4862) 41-00-56 Phones : +7 (4862) 43-41-39 / 43-41-40

E-mail: [eletex@eletex.ru](mailto:eletex@eletex.ru) / [eltex@orel.ru](mailto:eltex@orel.ru); I-net: [www.eletex.ru](http://www.eletex.ru)

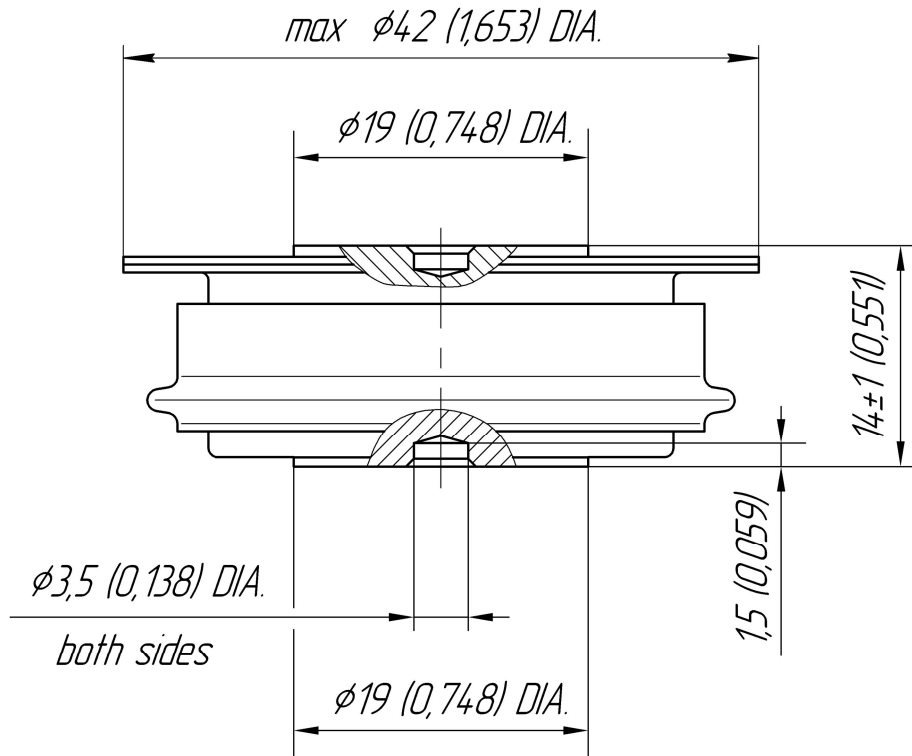

All dimensions in millimeters (inches)

The information contained herein is confidential and protected by Copyright.  
 In the interest of product improvement, Proton-Electrotex reserves the right to change data sheet without notice.

**JSC "PROTON-ELECTROTEX"**

19 Leskova, 302027, Orel, RUSSIA, Fax : +7 (4862) 41-00-56 Phones : +7 (4862) 43-41-39 / 43-41-40

E-mail: [eletex@eletex.ru](mailto:eletex@eletex.ru) / [eltex@orel.ru](mailto:eltex@orel.ru); I-net: [www.eletex.ru](http://www.eletex.ru)